

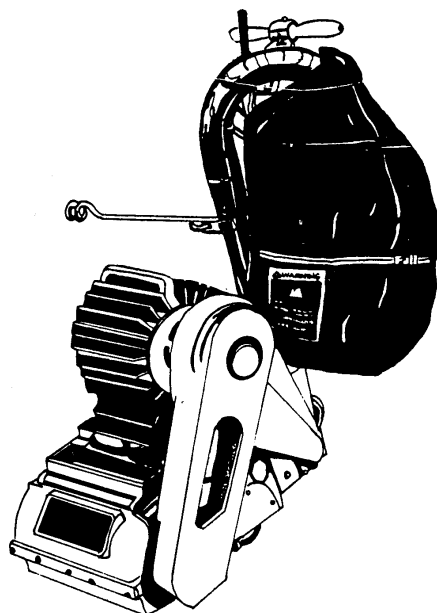

**Service  
Manual**



**American  
12**

### **READ THIS BOOK**

This book has important information for the use and safe operation of this machine. Failure to read this book prior to operating or attempting any service or maintenance procedure to your ALTO machine could result in injury to you or to other personnel; damage to the machine or to other property could occur as well. You must have training in the operation of this machine before using it. If operator(s) cannot read this manual, have it explained fully before attempting to operate this machine.

Si Ud. o sus operadores no pueden leer el Inglés, se hagan explicar este manual completamente antes de tratar el manejo o servicio de esta máquina.

All directions given in this book are as seen from the operator's position at the rear of the machine.

For new books write to: ALTO U.S. INC., 2100 Highway 265, Springdale, Arkansas 72764.

AMERICAN SANDERS TECHNOLOGY  
Model American 12 Floor Sander  
Drawing #1 Handle Assembly 10/00

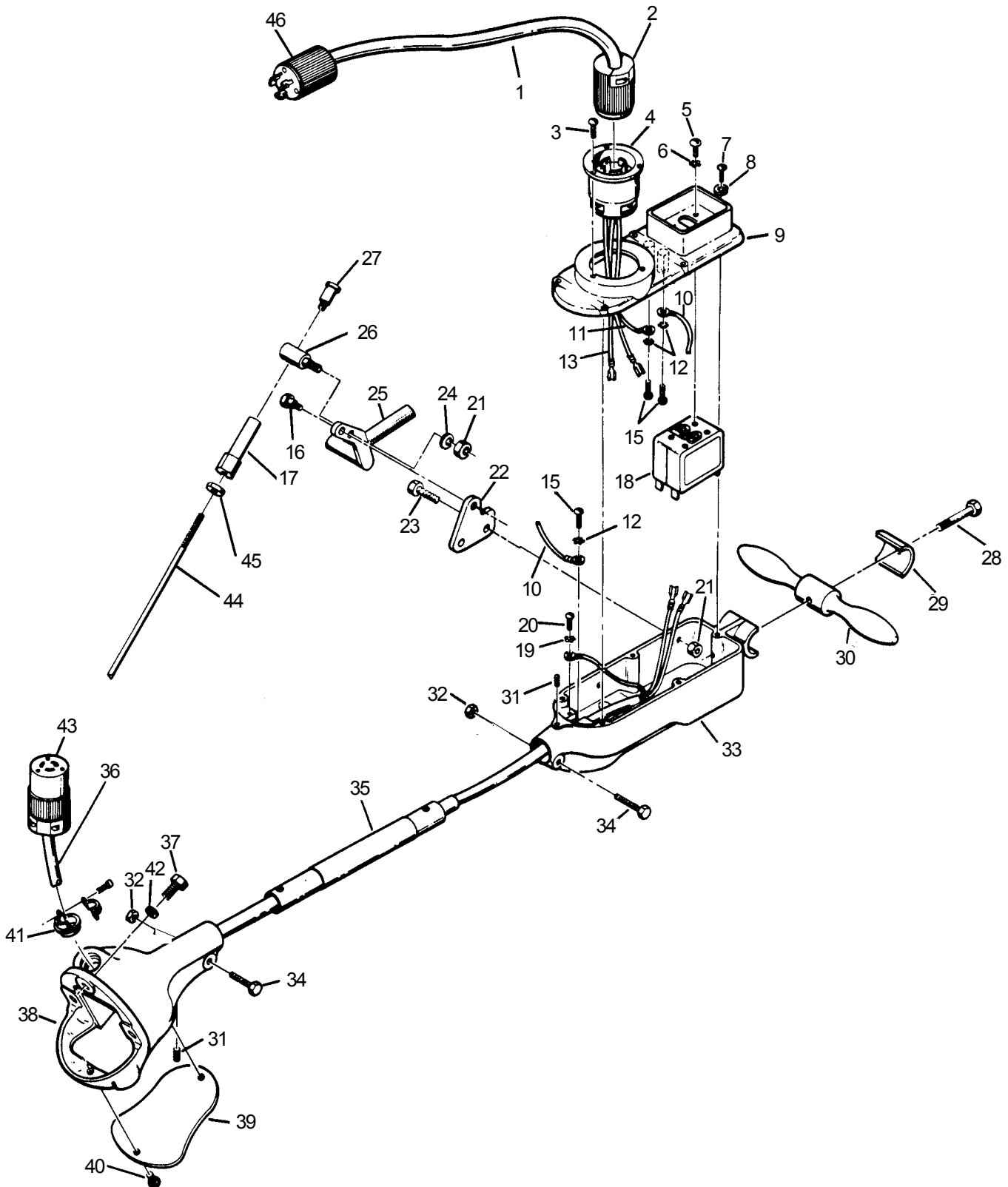

**IVIE Enterprises**

[www.ivie-ent.com](http://www.ivie-ent.com) Ph:(918)254-5161 or (888)262-5161 Fax:(918)250-4807

**AMERICAN SANDERS TECHNOLOGY**  
**Model American 12 Floor Sander**  
**Parts List #1 Handle Asembly 10/00**

Ref No.	Part No	Description	Qty
1	Ref.	Cord Assembly	1
2	41706A	Connector (NEMA)	1
3	962065	Screw - 8-32 x ¼ Pn St Mach	3
4	43501A	Inlet - 20A, 250V	1
5	85313C	Screw - 6-32 x ¼ Pn St Mach	4
6	980607	Washer - #1106 Shakeproof	4
7	962794	Screw - 10-24 x 1 Pn St	5
8	980650	Washer - ³/₁₆ Lock	5
9	22127C	Cover - Switch Box	1
10	48901A	Wire Ass'y - Green	1
11	48900A	Wire Assembly - Ground	1
12	980699	Washer - #1210 Shakeproof	3
13	49023A	Wire Assembly Black	2
15	962015	Screw - 10-24 x ³/₈	3
16	80022A	Bolt ½ x ⁵/₈	1
17	67129A	Adjuster Control Rod	1
18	41411A	Switch - Circuit Breaker	1
19	980603	Washer #8 Shakeproof	1
20	85833A	Screw, #10-32 Ground	1
21	920284	Nut ¼-20	2
22	66694A	Plate Control Lever	1
23	962481	Screw ¼-20 x 1¼	2
24	980646	Washer ¼	1
25	25602A	Lever Control	1
26	66151A	Pivot Control Rod	1
27	80021A	Bolt ³/₈ x ⁵/₈	1
28	85818A	Screw ⁵/₁₆-18 x 2¼ Hex St	1
29	21904C	Clamp - Handle	1
30	64405A	Handle - Steering	1
31	86200A	Screw - ³/₈-16 Set St	2
32	920110	Nut ⁵/₁₆-18 ESNA	2
33	20704C	Box - Switch	1
34	85816A	Screw ⁵/₁₆-18 x ¼ Hex St Flt Hd	2
35	66114C	Pipe - Handle	1
36	41917A	Cord - Interconnecting	1
37	962288	Screw ³/₈-16 x 1" Hex St Cap	3
38	21102C	Bracket - Handle	1
39	62609A	Cover, Handle Bracket	1
40	962016	Screw 10-24 x ½ Pn St Mach	2
41	170637	Connector, Conduit	1
42	980638	Washer - ³/₈ Diameter Lock	3
43	41707A	Connector	1
44	67144A	Rod Control	1
45	920148	Nut ³/₈-16 Jam	1
46	45608A	Plug (NEMA)	1

**IVIE Enterprises**

[www.ivie-ent.com](http://www.ivie-ent.com) Ph:(918)254-5161 or (888)262-5161 Fax:(918)250-4807

**AMERICAN SANDERSTECHNOLOGY**  
**Model American 12 Floor Sander**  
**Drawing #2 10/00**

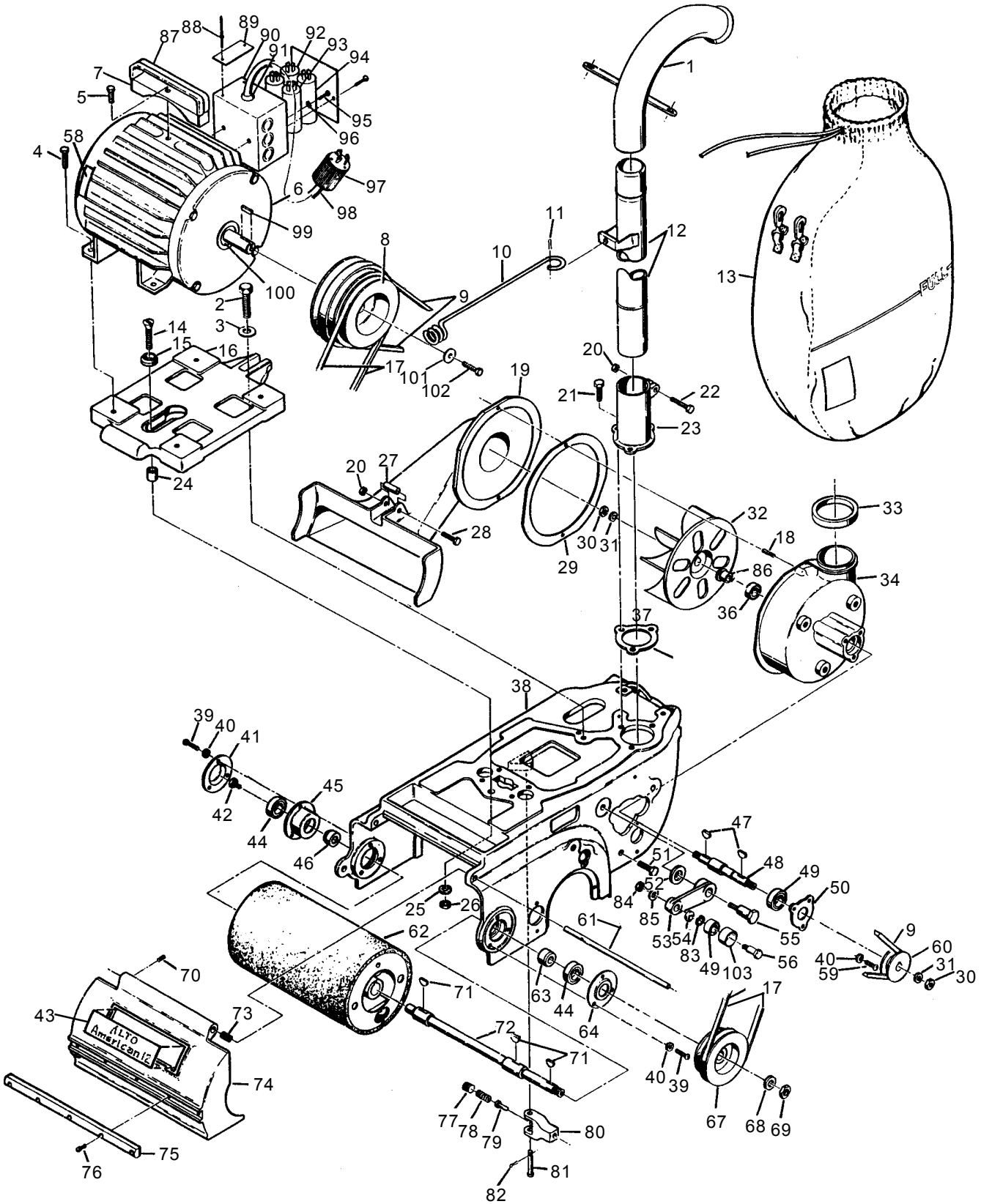

**AMERICAN SANDERS TECHNOLOGY**  
**Model American 12 Floor Sander**  
**Parts List #2 10/00**

Ref #	Part No.	Description	Qty
1	62800A	Pipe, Ass'y	1
2	85714A	Screw, 1/2 - 13 x 2 1/4 Hex	1
3	87006A	Washer, .56 X 1.38 X .11 Flat	1
4	962216	Screw 3/8 -16 x 1 1/4 Hex	4
5	962870	Screw 3/8-16 x 1	1
6	44639A	Motor 4 hp 230V/60	1
	44640A	Motor 3 hp 240V/50	1
7	64460A	Handle, Motor	1
8	66164A	Pulley, Motor	1
9	51028A	Belt-V	1
10	60401A	Arm, Cable	1
11	925044	Pin, 3/32 x 1 Cotter	1
12	66110A	Pipe Assembly	1
13	50954A	Dust Bag	1
14	84220A	Screw, 1/2-13 x 2 1/4 Ft.	1
15	68704A	Washer - Motor Screw	1
16	26108C	Platform, Motor	1
17	51021A	Belt - V	1
18	68002A	Stud	1
19	26102A	Pan, Dust	1
20	920256	Nut, 5/16-18 Hex	2
21	85820A	Screw, 3/8-16 x 5/8 Hex	3
22	85816A	Screw, 5/16-18 x 1 3/4 Hex	1
23	27801C	Support, Dust Pipe	1
24	67820A	Spacer, Motor Screw	1
25	87101A	Washer, 1/2 Lock	1
26	920196	Nut, 1/2-13 Hex Jam	1
27	30501A	Bushing	1
28	85817A	Screw, 5/16-18 x 2" Hex	1
29	34224A	Gasket	1
30	81202A	Nut, 7/16-14 Hex L.H.	2
31	87002A	Washer	2
32	23300A	Fan	1
33	39704A	Washer, Felt	1
34	24504C	Housing, Fan	1
36	902567	Bearing	1
37	34223A	Gasket, Support Pipe	1
38	23406C	Frame	1
39	962983	Screw, 1/4-20 x 5/8 Pan	6
N	18601A	Shaft Ass'y Drum (1) includes D56, D39, D71	
40	980657	Washer, 1/4 Lock	9
41	62608C	Cover, Drum Housing	1
42	67314A	Screw, Special	1
43	70042A	Label, I.D. American 12	1
44	51110A	Bearing	2
45	64703A	Housing, Bearing	1
46	67818A	Spacer, Drum Shaft	1
47	915028	Key - #5 Woodruff	2
48	67424A	Shaft Fan	1
49	51111A	Bearing	2
50	62001A	Cap, Bearing	1

Ref #	Part No.	Description	Qty
51	962288	Screw, 3/8-16 x 1" Hex	2
52	67816A	Spacer	1
53	20401B	Arm	1
54	67815A	Spacer, Idler Bearing	1
55	68101A	Stud	1
56	67413A	Shaft	1
57*	38109A	Seal, Dust Pipe	1
58	77234A	Label, Lifting Warning	1
59	962823	Screw, 1/4-20 x 1/2 Pan	3
60	66172A	Pulley, Fan Shaft	1
61	67417A	Shaft, Drum Cover	1
62	13500A	Drum Assembly	1
63	67819A	Spacer, Drum Shaft	1
64	66918A	Retainer, Bearing	1
65			
66			
67	66165A	Pulley, Drum	1
68	980644	Washer, 5/8 Plain	1
69	920280	Nut, 5/8-18 Hex Jam	1
70	962262	Screw, 8-32 x 1/4 Set	1
71	55400A	Key - #9 Woodruff	3
72	67415A	Shaft, Drum	1
73	67911A	Spring	1
74	22111A	Cover, Drum	1
75	31211A	Bumper Assembly	1
76	85517A	Screw, 10-24 x 1/2 PN	5
77	86202A	Screw, Set 5/8-11	1
78	67908A	Spring	1
79	66115A	Plunger	1
80	29402A	Yoke	1
81	66505A	Pin, Yoke	1
82	925036	Pin, 3/32 x 3/4 Cotter	1
83	877304	Ring Retaining	1
84	920148	Nut, 3/8-16 Hex Jam	1
85	87000A	Washer	1
86	61602A	Collar	1
87	32357A	Cover Handle	1
88	930087	Rivet	2
89	74044A	Plate Safety	1
90	62904A	Enclosure Motor	1
91	697502	Strain Relief Bushing	1
92	41305A	Capacitor, Start	2
93	41304A	Capacitor, Run	1
94	47378A	Switch, Start	1
95	962823	Screw, 1/4-20 X 1/2	2
96	980614	Washer	2
97	45604A	Plug	1
98	41945A	Cord, Motor	1
99	915098	Key, 1/4 Sq. x 1 1/4	1
100	57712A	Ring, Retaining	1
101	87034A	Retainer Pulley	1
102	962288	Screw, 3/8-16 x 1	1
103	66173A	Pulley Idler	1

\*NOTE: #57 Not Illustrated

**Motor Parts Not Illustrated**

Part #	Description	Qty.
50563A	End Bell	1
52768A	Front Cover	1
53998A	Fan	1
52769A	Fan Cover	1

Part #	Description	Qty.
51188A	Bearing Front	1
902547	Bearing Rear	1
40316A	Armature Assembly	1

**AMERICAN SANDERS TECHNOLOGY**  
**American 12 Floor Sander**  
**Assembly Drawing #3 6/01**

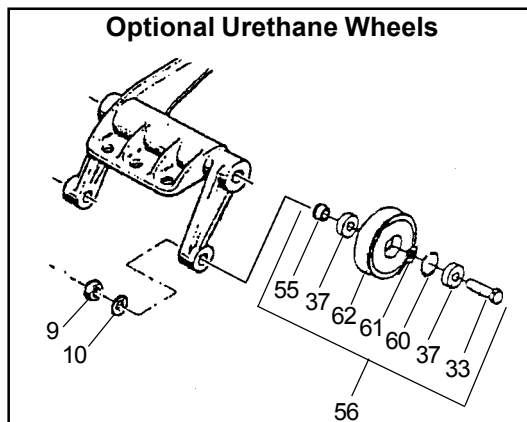
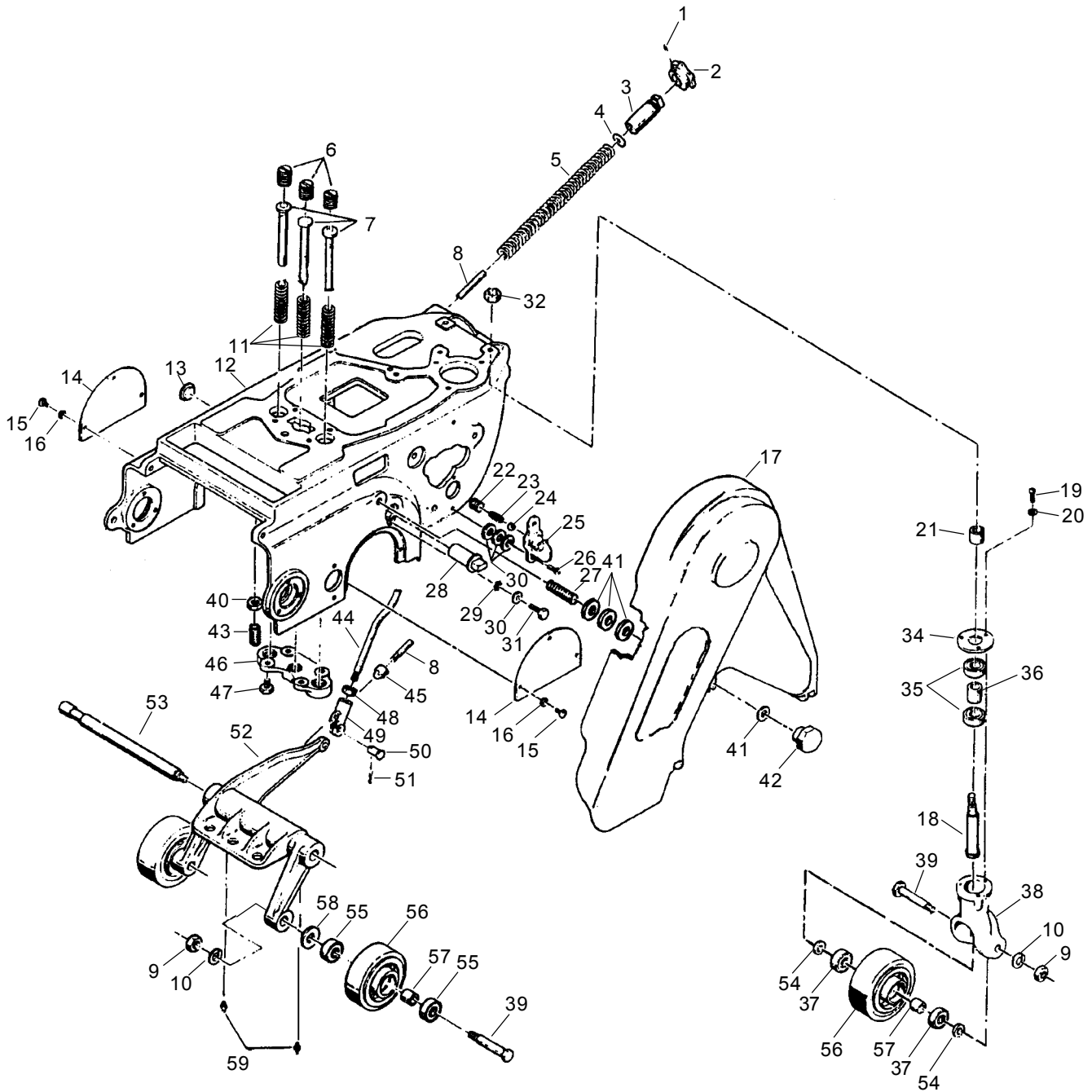

**AMERICAN SANDERS TECHNOLOGY**  
**American 12 Floor Sander**  
**Assembly Parts List #3 6/01**

Ref. No	Part No.	Description		
			Qty	Qty
1	88502A	Screw, 10-24 x 3/8 Set	2	2
2	25200C	Knob, Hand	1	1
3	67309A	Screw, Sustainer	1	1
4	87000A	Washer	1	1
5	67907A	Spring, Sustainer	1	1
6	67315A	Screw	3	3
7	66123A	Plunger, Spring	3	3
8	67109A	Rod, Pilot	1	1
9	920196	Nut, 1/2-13 Hex Jam	3	3
10	87101A	Washer, 1/2 Lock	3	3
11	67906A	Spring	3	3
12	Ref.	Frame, Main	1	1
13	57100A	Button, Plug	1	1
14	66628C	Plate, Cover Wheel	2	2
15	962015	Screw, 10-24 x 3/8 Pn St Mach	6	8
16	980650	Washer, 3/16 Lock	6	6
17	23801A	Guard, Belt	1	1
18	60715B	Bolt, Pivot	1	1
19	962823	Screw, 1/4-20 x 1/2 Pn St Mach	3	3
20	980657	Washer, 1/2 Lock	3	8
21	67814A	Spacer	1	1
22	86202A	Screw, 5/8-11 x 5/8 St	2	2
23	67909A	Spring	2	2
24	51113A	Ball, 1/2 Diameter	2	2
25	21902C	Clamp	2	2
26	962892	Screw, 1/4-20 x 5/8 Pn St Mach	4	4
27	68001A	Stud, Belt Guard	1	1
28	62801A	Shaft, Cont. Ecc.	1	1
29	980614	Washer, #1114 Shakeproof	1	1
30	87007A	Washer, Cont. Shaft Ecc.	13	13
31	85806A	Screw, 1/4-20 x 1 Hex St	1	1
32	81209A	Nut, Large Flange 1/2-13	1	1
33◆	60547A	Axle	-	2
34	66913A	Retainer, Bearing	1	1
35	51112A	Bearing	2	2
36	67821A	Spacer	1	1
37◆	51225A	Bearing, Ball	6	6
38	29403C	Yoke, Wheel	1	-
39	60101A	Axle	3	1
40	920160	Nut, 5/16-18 Hex JAM	1	1
41	87006A	Washer, 9/16 x 1 3/8 x 10	ref.	ref.
42	26000C	Nut, Retaining	1	1
43	86201A	Screw, 5/16-18 Set	1	1
44	67144A	Rod, Control	1	1
45	62000A	Nut, End	1	1
46	26502A	Plate, Plunger	1	1
47	85811A	Screw, 5/16-18 x 3/4 Hex St Cap	4	4
48	920260	Nut, 3/8-16 Hex	1	1
49	53917B	Fork, Control	1	1
50	66503A	Pin, Fork	1	1
51	925036	Pin, 3/32 x 3/4 Cotter	1	1
52	25600A	Lever, Reach	1	1
53	67416A	Shaft, Lever	1	1
54	67810A	Spacer	2	2
55◆	60544A	Spacer	-	2
56	59928A	Wheel (Steel)	3	-
◆	10243A	Kit, Wheel (Urethane) (Optional)	-	-
	59907A	Wheel (Canvas)	-	1
57	67817A	Spacer	3	3
58	87003A	Washer	2	2
59	54000A	Fitting, Grease	2	2
60◆	167312	Ring, Retainer	2	2
61◆	60481A	Spacer	2	2
62◆	50992A	Wheel, Assembly	-	2

**NOTE:**

◆ indicates a change has been made since the last publication of this manual.

**AMERICAN SANDERS TECHNOLOGY**  
**American 12 Floor Sander**  
**Accessories Drawing & Parts List #4 10/00**

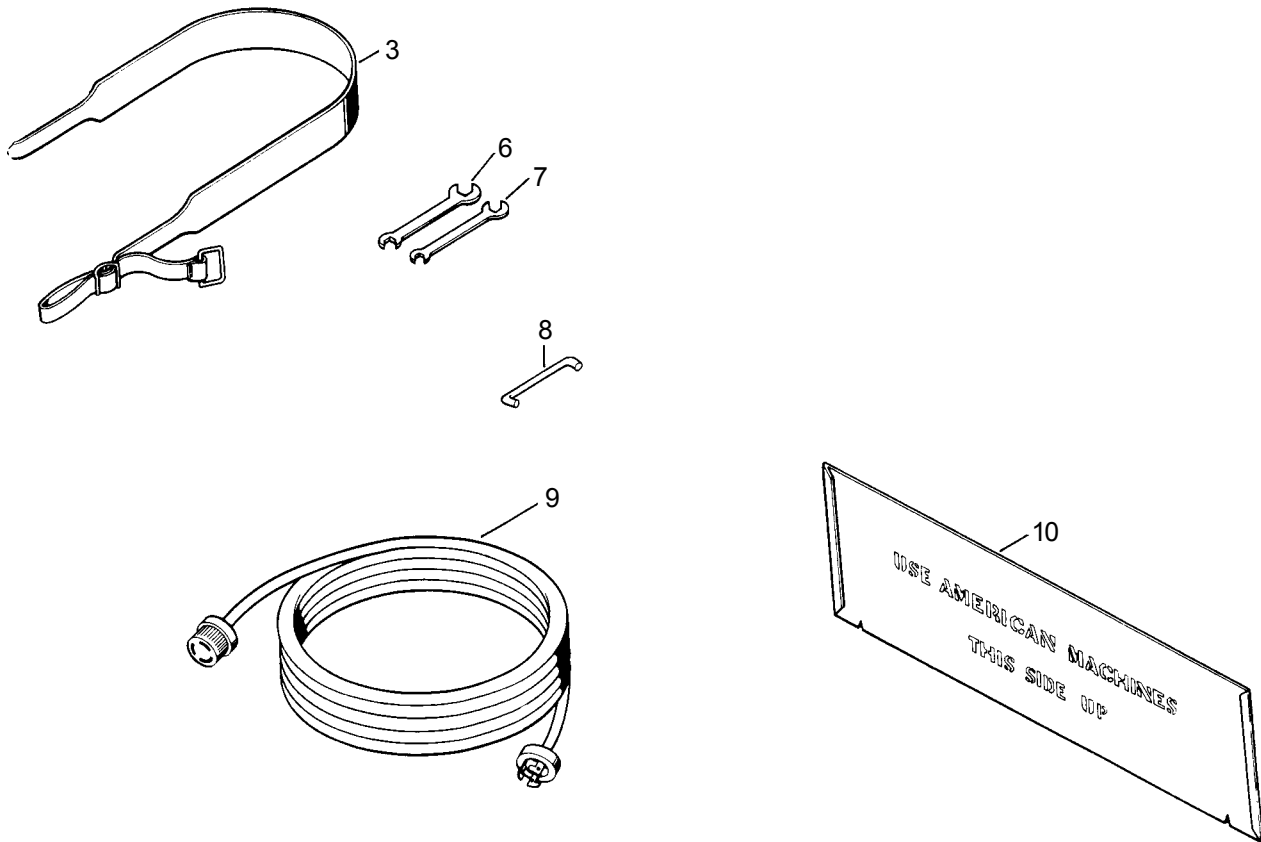

Ref. #	Part No.	Description	Qty
1			
2			
3	60724A	Belt, Operating	1
5			
6	59810A	Wrench, Paper Clamp	1
7	59811A	Wrench, End $\frac{3}{4} \times \frac{7}{16}$	1
8	64415A	Handle, Carrying	1
9	42201A	Cord Assembly (NEMA)	1
	42302A	Cordset, 240/50	1
10	68314A	Template	1

**IVIE Enterprises**

[www.ivie-ent.com](http://www.ivie-ent.com) Ph:(918)254-5161 or (888)262-5161 Fax:(918)250-4807

## Chatter □ Wave Prevention

American Sanders Technology Sanders are designed and manufactured to the most rigid tolerances. However, after a finishing cut it is possible to see “chatter” or “waves”.

The best guarantee to remove the chatter is to finish the floor with a rotating horizontal sander, such as American Sanders Technology’s Sander 16.

To minimize chatter when using a belt or drum sander the following steps should be taken:

- 1) DRUM PAPER...insure the paper is secured in the slot, but not too tight. Paper that is too tight will force the drum slot wider, leaving a “slot mark chatter” on the floor.

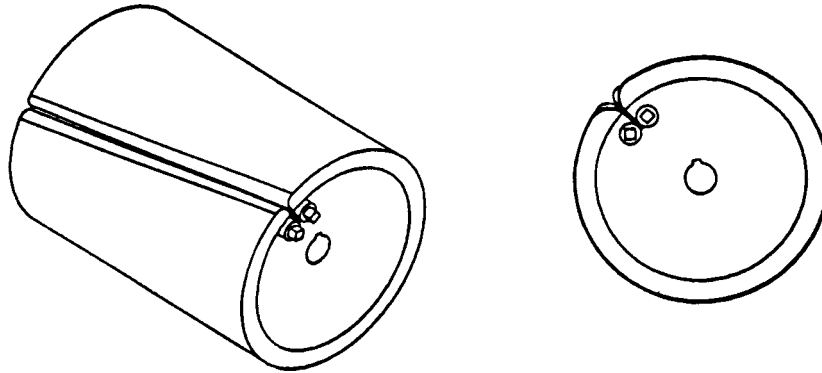

- 2) DRUM MARKS.....are caused by the operator lowering the drum to the floor without forward traverse. These marks should be removed by cutting at a 45 degree angle to the mark. Cutting at the mark while maintaining the same path will only increase the mark depth and width.

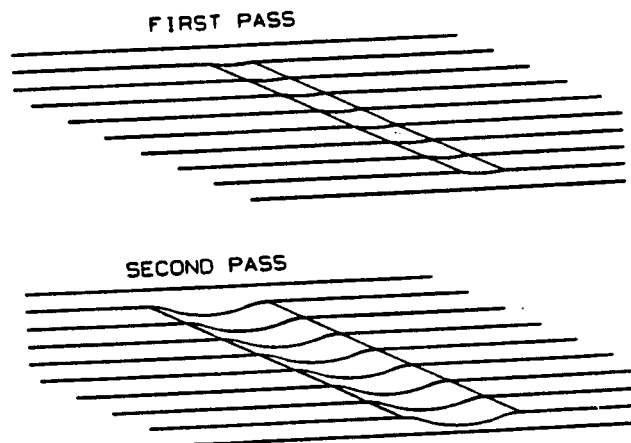

## IVIE Enterprises

[www.ivie-ent.com](http://www.ivie-ent.com) Ph:(918)254-5161 or (888)262-5161 Fax:(918)250-4807

### Chatter Wave Prevention (cont)

- 3) UNEVEN WALKING PACE..... can leave lengthy “waves”. The machine cuts more material during the slower pace. Pay particular attention to a steady, even pace.
- 4) EXCESSIVE LIGHT CUTS.... may reveal high spots on the paper/contact wheel and cause chatter. Take a heavier cut and increase the pace.
- 5) DEBRIS.... lodged between the paper and the drum will leave chatter. On a belt sander, debris may be adhered to the drum. Insure the drum is clean and free of debris before placing the paper on.
- 6) SANDER PAPER QUALITY....may vary. Belt seams can be thicker on low quality paper and cause chatter. Use only American Sanders Technology specified sandpaper.

### PROPER CARE OF YOUR MACHINE CAN MINIMIZE CHATTER AND WAVES.

- 1) V-BELTS.... can cause vibration and chatter if they are of low quality. Use only belts specified by American Sanders Technology.
- 2) TRUCK AND CASTER WHEELS....with flat spots, out-of-roundness, or debris adhered to their surface can cause “waves” or a “chatter effect”. Always clean and inspect all wheels before starting to sand, and before the finish cut. Replace or true the wheels if found to be out-of-round.
- 3) DUST PICK-UP SHOES.....may need adjusted differently for different materials that are to be sanded. An improperly adjusted shoe will leave trailing debris that will be run over by the wheels and cause “random waves”.
- 4) CONTACT WHEELS (DRUMS).....may be out-of-round and cause “chatter”. Contact your American Sanders Technology dealer for assistance to true or replace the drum.
- 5) BEARINGS.....in the motor, drum, or fan system may become worn and induce vibration which could cause “chatter”.
- 6) PULLEYS.....that are damaged or severely worn can induce vibration and cause “chatter”. Contact your American Sanders Technology dealer for assistance.

**American Sanders Technology is not responsible for rework of floors that are unacceptable to the customer. It is your responsibility to insure your equipment is in proper operating order, and that you use the right machine for the job.**

### **IVIE Enterprises**

[www.ivie-ent.com](http://www.ivie-ent.com) Ph:(918)254-5161 or (888)262-5161 Fax:(918)250-4807