IVIE Enterprises
www.ivie-ent.com Ph:(918)254-5161 or (888)262-5161 Fax:(918)250-4807



Super 7R
Edger
Section II
Parts and Service Manual

(78155B)

MAINTENANCE

CAUTION: Maintenance and repairs performed by unauthorized personnel could result in damage or injury. Maintenance and repairs performed by unauthorized personnel will void your warranty. Failure to perform maintenance at recommended intervals may void warranty.

Carbon Brushes

Inspect all four brushes every 6 months or 250 hours. Access to the brushes is gained through the front and back motor vent plugs and under both motor covers (figure 6). Press tab on spring clip assembly in, rotate, then remove (figure 7). Use needlenose pliers to disconnect the shunt wire. If any brush has worn to 3/8" in length or shorter, replace the entire set.

CAUTION: Use only motor brush PN 40818A or PN 40055A with shunt wire or motor failure will occur.

When replacing the brushes make sure that the brush seats against the commutator, the spring rest in the recess of the brush, and the brush is free to travel. When returning the switch cover, keep any wires clear of the commutator and any pinch site.

To Change The Lubricant In The Gearbox

To change the lubricant in the gearbox, follow this procedure:

1. Put the machine upside down on a bench.
2. Align one of the two holes in the rubber pad with one of the three holes in the rotating wall guard.
3. Align both holes with one of the three screws in the gear housing cover. Remove the screw from the gear housing cover. (Figure 8)
4. Align the holes with each of the other two screws, then remove screws.

CAUTION: Make sure no dust enters the gear box. Damage will occur to the gear box.

5. Remove the cover from the gear housing.
6. Remove the old lubricant from the gearbox.
7. Add six ounces of American Sanders Technology lubricant to the gear box.

CAUTION: To prevent damage to the motor, do not add more than six ounces of lubricant to the gearbox.

8. Using the three screws removed above, install the cover on the gear housing.
9. Start the machine and let it run for 15 minutes. A small amount of excess lubricant should flow out the vent hole. If none appears it may be necessary to add additional lubricant.
10. Wipe off excess lubricant and clear vent hole.

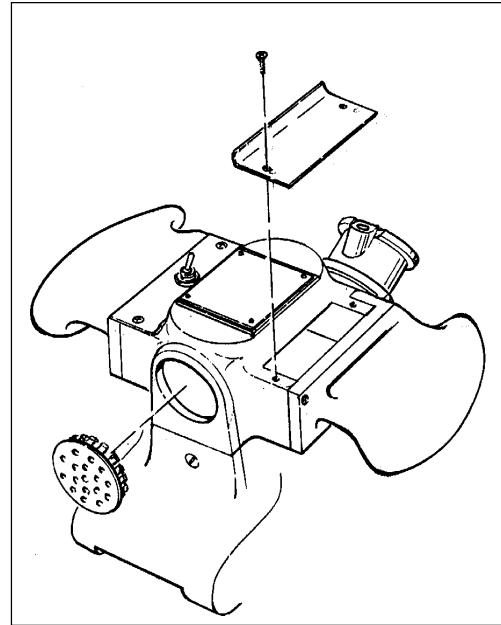

Figure 6

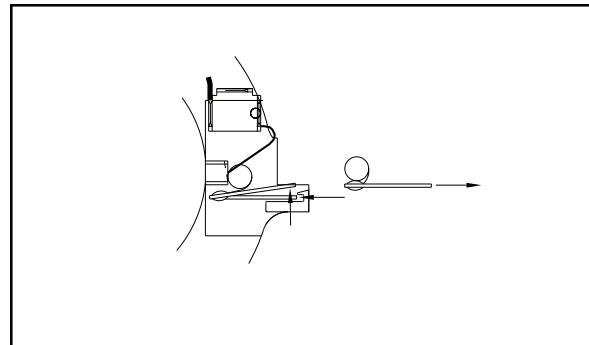

Figure 7

Lubricants

Qty	Part No.
1Qt.	16610A
1Gal.	16611A

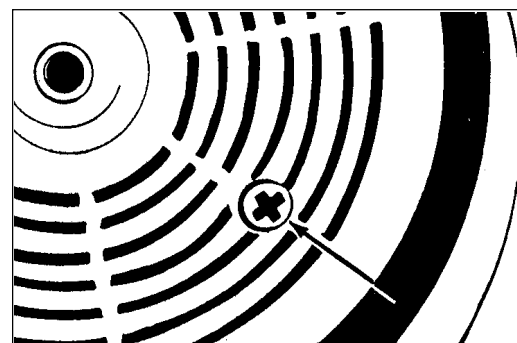
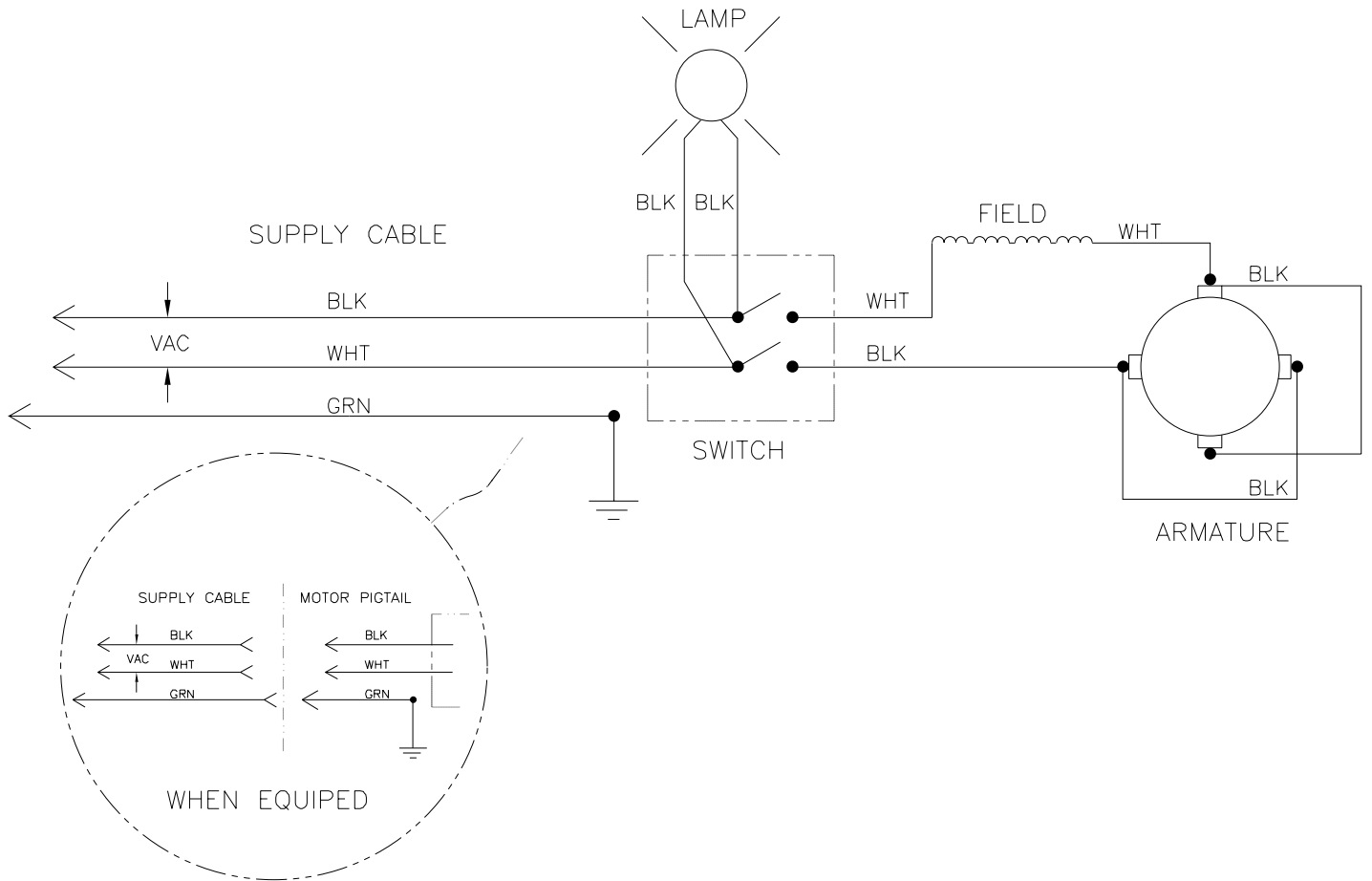

Figure 8

AMERICANSANDERSTECHNOLOGY
Model Super 7R Edger
Wiring Diagram 9/96



IVIE Enterprises

www.ivie-ent.com

Ph:(918)254-5161 or (888)262-5161 Fax:(918)250-4807

AMERICAN SANDERS TECHNOLOGY
 Super 7R Edger
 Drawing - 10/01

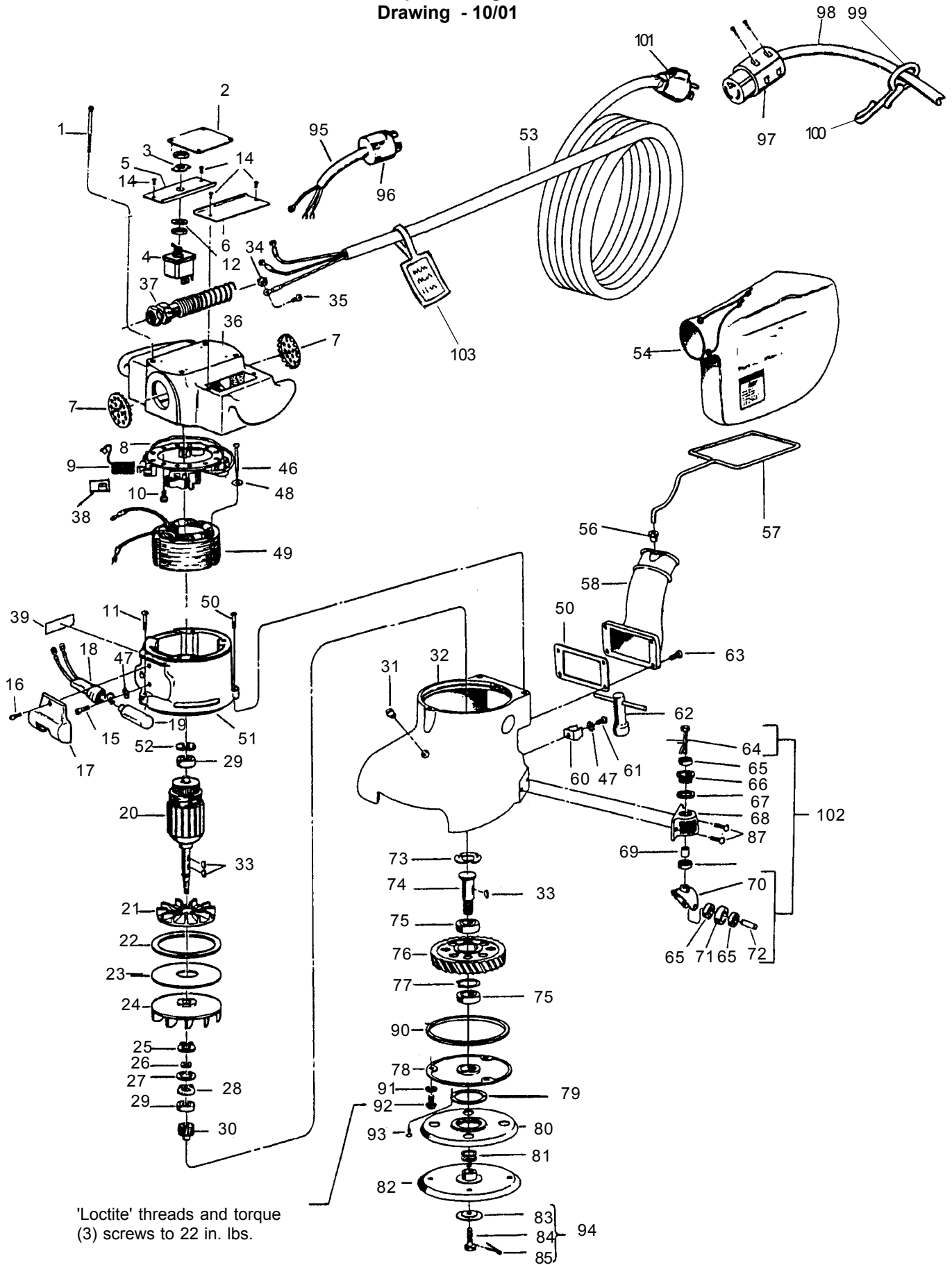

'Loctite' threads and torque
 (3) screws to 22 in. lbs.

AMERICAN SANDERS TECHNOLOGY

Super 7R Edger

Parts List - 7/00

Ref#	Part No.	Description	Qty
1	962404	Screw - #10-24 x 3 1/4 Ft. St. Mach.	4
2	70054A	Plate - Name	1
3	646302	Plate - Dial	1
4	47394A	Switch - Toggle	1
5	302310	Cover, Motor Brush R.H.	1
6	302309	Cover, Motor Brush L.H.	1
7	306802	Plug - Vent	2
8	43201A	Holder Assembly Brush	1
9	40818A	Brush - Motor 115V	4
	40055A	Carbon Brush 240V	4
10	962727	Screw - #8-32 x 1/2 Pan Head	4
11	962988	Screw - 1/4 -20 x 1 1/4 Pan St. Mach.	1
12	980662	Washer - SH #1224-00 Lock	1
13			
14	962545	Screw - #6-32 x 3/8 Ft. St. Type 23	4
15	85393A	Screw - #10-24 x 1/4 Pn. St. Mach.	1
16	962310	Screw - #10-24 x 1/2 OV	1
17	303602	Guard - Lamp	1
18	46902A	Socket -Assembly	1
19	911113	Bulb - Light 15W Clear	1
	911116	Lamp 240V	1
20	10101B	Armature Assembly-w/Fan - 115V	1
	10110A	Armature Assembly-w/Fan - 240V	1
21	303004	Fan - Motor	1
22	293403	Gasket - Fan Baffle	1
23	306102	Plate - Exhaust Fan Baffle	1
24	303002	Fan - Vacuum	1
25	307302	Ring - Retaining	1
26	308202	Spacer - Bearing	1
27	297604	Seal - Oil	1
28	407302	Ring - Retaining	1
29	902567	Bearing	2
30	293514	Pinion - Armature	1
31	316804	Plug - Pipe 1/8	1
32	304204	Housing - Gear	1
33	915028	Key 1/8 x 5/8 Woodruff	3
34	980621	Washer, #1108	1
35	962550	Screw, 8-32 x 5/16	1
36	302312	Cover - Handle Assembly Polish	1
37	467504	Strain Relief	1
	56475A	Strain Relief 240V	1
38	50932A	Spring brush Holder	4
39	73285A	Label, Warning	1
46	962211	Screw - #10-24 x 2 1/2 Pn. St. Mach.	2
47	980603	Washer - #1110 Shakeproof	7
48	980643	Washer - #10 7/16 Plain	2
49	42819A	Field assembly - 240 Volt	1
	42820A	Field Assembly - 115 Volt	1
50	962454	Screw - 1/4-20 x 1 Sc. Cap	2
51	304208	Housing and Guard Assembly	1
	20013A	Housing, Motor Super7R	1
52	298306	Spring Load	1

Ref#	Part No.	Description	Qty
53	42018A	Cord Assembly, 115V	1
54	50952A	Bag, Dust	1
56	50732A	Bearing	1
57	69621A	Support, Bag	1
58	21108A	Bracket - Exhaust	1
59	293406	Gasket - Exhaust Bracket	1
60	302101	Clamp - Wrench	1
61	962987	Screw - 10-24 x 3/8 Pn. St. Typ.	1
62	987300	Wrench	1
63	962289	Screw - 1/4-20 x 3/4 Soc. St. Cap	4
64	85702A	Screw - 1/4-20 x 1 1/4	2
65	50740A	Bearing	8
66	960130	Screw - Caster Adjusting	2
67	920670	Nut - Lock Adjust	2
68	310803	Bracket - Caster Support	2
69	298215	Spacer - Collar	2
70	29404A	Yoke, Edger, Caster	2
71	299704	Roller - Caster	2
72	925592	Pin - 1/4 x 1 Spirol	2
73	318303	Spring - Load	1
74	307702	Shaft - Drive Gear	1
75	902550	Bearing	2
76	303502	Gear - Drive	1
77	067304	Ring - Retaining	1
78	302306	Cover - Assembly Gear Housing	1
79	317204	Retainer - Disc Guard	1
80	293616	Guard - Disc	1
81	980088	Washer	2
82	13203A	Assembly - Sanding Pad	1
83	980132	Washer - Disc, Retaining	1
84	960140	Screw - Paper Lock	1
85	925004	Pin - Cotter 1/16 x 1/2	1
87	962109	Screw - #10-24 x 5/8 Pn SS	4
90	34232A	Gasket - Gear Case Cover	4
91	87609A	Washer Seal	3
92	84808A	Screw, 10-24 x 3/4	3
93	962974	Screw, 6-32 x 1/2	4
94	960125	Assembly Screw Lock	1
95	41947A	Cord Interconnect 240 V	1
96	45602A	Plug 240 V	1
97	41708A	Connector 240V	1
98	42182A	Cord Assembly Power 240V	1
	40007A	Cordset, 50' w/AU1-10P	1
99	57809A	Ring	1
100	54812A	Hook	1
101	911248	Plug 115V	1
102	12208A	Caster Assembly	2
103◆	70175A	Tag, Warning	1
NI	31407A	Case, Super 7R Edger	1
NI◆	40023A	Plug, AU1 -10P	1

NI = Not illustrated

NOTE: Assembly 12208A includes parts 64, 65, 70, 71, & 72

NOTE: ◆ indicates a change has been made since last publication of this manual.

Accessories Available

	Part No.	Description	Qty
	312404	Cutter Disc Assembly	1
a	311306	Blade - Disc Cutter	1
b	312904	Eject Disc Cutter	1
c	315604	Mallet	1
d	317004	Punch Center	1
e	317304	Ring Disc Cutter	1
f	762005	Clamp	1
g	920208	Nut - 1/4-20 Hex	1
h	962013	Screw 1/4-20 x 1 1/4 R	1
i	962233	Screw 1/4-20 x 5/16 S	1