

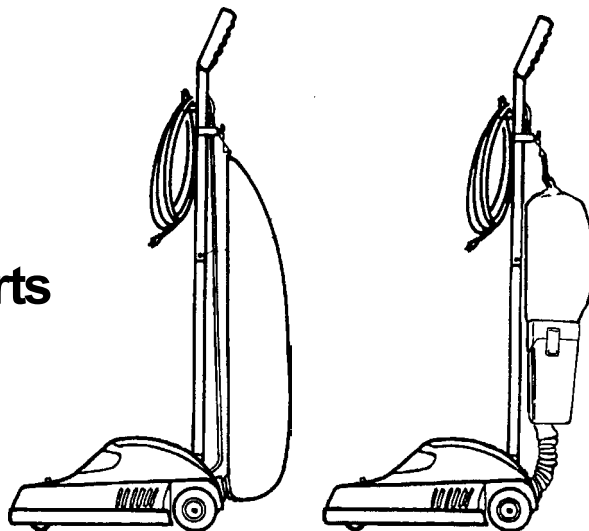

## Repair Parts List



## 530 / 530cc Upright Vacuum

### READ THIS BOOK

This book has important information for the use and safe operation of this machine. Failure to read this book prior to operating or attempting any service or maintenance procedure to your ALTO machine could result in injury to you or to other personnel; damage to the machine or to other property could occur as well. You must have training in the operation of this machine before using it. If operator(s) cannot read English, have this manual explained fully before attempting to operate this machine.

All directions given in this book are as seen from the operator's position at the rear of the machine.

For new books write to: ALTO U.S. Inc., 2100 Highway 265, Springdale, Arkansas 72764.

## Table of Contents

Final Test for Product Safety .....	3
Replacement Procedures .....	3
To Disassemble the Motor .....	4
530 Upright Vacuum External Parts .....	5
530 Upright Vacuum Internal Parts .....	6
530 Upright Motor Assembly.....	8
Trouble Shooting Guide .....	9
Wiring Diagram .....	9
530cc Drawing Assembly and Parts List.....	10

### **IVIE Enterprises**

[www.ivie-ent.com](http://www.ivie-ent.com) Ph:(918)254-5161 or (888)262-5161 Fax:(918)250-4807

## FINAL TEST FOR PRODUCT SAFETY

At the completion of any repairs the product should be electrically tested for running and electric strength as follows:

### Electric Strength

1. Set hi-pot test meter to 1500 volts.
2. Product switch to ON-position.
3. Touch one probe of tester to one blade of power cord plug and touch other probe to handle tube. There should be no breakdown.

### Running

Run the machine with the height adjustment knob on high and check:

1. There should be no abnormal noise or vibration.
2. The carbon brushes spark should be small and uniform.
3. The current should not exceed 9.0 amps.

**NOTE:** The letters with the item no., references, identify item number on internal (I), external (E) or motor (M) illustrations.

## REPLACEMENT PROCEDURES

- 1. To Remove Bag (30-E).**  
Release Spring (36-E) from handle, turn knob on bag coupling ccw (25-E), slide coupling off unit.
- 2. To Remove Handle Tube (7-E, 10-E).**
  - a. Disengage line cord from line cord retainer (3E) pulling cord outward from retainer bottom.
  - b. Remove bolt and nut (8E and 9E) on handle socket (24-I) and pull tube out.
- 3. To Replace The Belt (39-I)**
  - a. Place upright on hood so wheels face upward. Make sure to place on protected surface not to damage hood.
  - b. Remove retaining bar (58-I) by pressing down on right side (longest), remove brush roll cover (57-I) and fan cover (38-I).
  - c. Stretch and twist belt over motor pulley (15-M) to pull it out. (If not broken).
  - d. Remove complete brush roll (52-I) with bearing supports (54-I) pulling it out near the bearings.
  - e. Place new belt on roll, replace roll on chassis making sure the mark "top" on bearings support faces towards the brush roll cover and reassemble.
- 4. To Replace the Brush Roll (52-I) or Bearing Supports (54-I).**
  - a. Follow steps indicated on point 3a and 3b.
  - b. Remove bearing support (54-I) pulling them away from brush roll (old or new).
  - c. Place bearing supports on new brush roll, place belt over roll and replace it on chassis following steps 3e.
- 5. To Replace Rear Wheels (16-I).**
  - a. Remove hood as in step 7.
  - b. Pull out retainer pin (19-I) from axle, and slide wheels outward.
  - c. Replace the new wheel and axle, and insert the pin.
  - d. Replace hood.
- 6. To Replace Front Wheels (42-E).**
  - a. Remove hood as in step 7.
  - b. Remove screws (44-I) from front axle supports (45-I) and take out axle assembly.
  - c. Remove cotter pin (43-E) and flat washer (59-I) and pull out wheel.
  - d. Replace the new front wheel, washer and cotter pin.
  - e. Replace axle assembly on chassis making sure springs (51 and 47-I) are in place.
  - f. Replace hood.
- 7. To Remove the Hood (17-E).**
  - a. Remove bag and handle tube as in steps 1 and 2.
  - b. Depress handle release pedal (31-I) and rotate socket (24-I) to horizontal position.
  - c. Remove screw from height adjustment knob (11-E) and pull out knob (12-E).
  - d. Place upright on hood so wheels face upward, make sure to place on protected surface not to damage hood.
  - e. Remove springs (18-E) from "V" tabs on chassis, turn upright holding hood and separate hood from chassis.
- 8. To Replace Motor (3-I).**
  - a. Remove belt as in steps 3a to 3c.
  - b. Remove hood as in step 7.
  - c. Release air ducts (1-I and 15-I) applying pressure on both sides and slide out.
  - d. Remove the four motor base screws (4-I) disconnect switch leads and pull out motor.
- 9. To Replace Height Adjustment Cam (13-I).**
  - a. Remove hood as in step 7.
  - b. Slide cam assembly out.
  - c. Replace new cam and reassemble.
- 10. To Replace Handle Release Pedal (31-I).**
  - a. Remove hood as in step 7.
  - b. Remove spring (32-I) from chassis.
  - c. Pull pedal towards spring slide and remove.

## REPLACEMENT PROCEDURES (cont.)

11. **To Replace Handle Socket (24-I).**
  - a. Remove hood as in step 7.
  - b. Remove handle release pedal as in step 10.
  - c. Remove "C" washers (17-I) from socket bolt (18-I) pull out bolt and remove socket.
12. **To Replace Handle Position Cam (27-I).**
  - a. Remove handle socket as in step 11.
  - b. Pull out "c" washer (30-I) and bolt (29-I) remove cam and cam spring (28-I).
  - c. When reassembling be sure spring (28-I) is located as before.
13. **To Replace the Line Cord (2A-I).**
  - a. Disengage line cord from retainer in handle as in step 2a.
  - b. Remove handle tube as in step 2.
  - c. Remove hood as in step 7.
  - d. Disconnect switch and ground leads.
  - e. Remove the insulating cover from switch lead forcing a sharp 1/16 needle to rise the rib inside the insulator and pull it out. (Or cut wire to insulated terminal leaving enough wire to reconnect.)
  - f. Remove Heyco strain relief (20-I) from chassis with Heyco pliers and slide it out of the line cord.
  - g. Slide strain reliefs and hook on the new line cord, and reassemble with the Heyco pliers making sure to locate the strain relief as it was before.
14. **To Replace the On-Off Switch (12-M).**
  - a. Remove hood as in step 7.
  - b. Disconnect the electrical terminal from switch.
  - c. Press the side tabs on the switch and pull it out.
  - d. Press the new switch on the opening until the tabs snap, and reconnect the terminal.
15. **To Replace the Switch Actuator (22-I).**
  - a. Remove hood as in step 7.
  - b. Remove "C" washer (25-I) from bolt (23) and slide out the bolt and the actuator assembly.
  - c. Replace the new actuator and assemble.

16. **To Replace the Fan.**
  - a. Remove the belt as in point 3 a , b and c.
  - b. Hold the fan (14-M) while turning loose the nut (15-M).
  - c. Remove nut and fan.
  - d. Remove the new fan and reassemble.

### 17. **Motor Servicing.**

The only possible motor repairs are :

- a. Replace carbon brushes.
- b. Replace armature.
- c. Replace field.

**NOTE:** Never try to repair the field or armature, if defective replace with a new one.

## TO DISASSEMBLE THE MOTOR

1. Remove motor as in point 8.
2. Hold the fan (14-M) while turning loose nut (15-M) and remove nut and fan.
3. Remove the electrical connection to carbon brushes pulling them out of the terminals.
4. Remove the brush holders support screws (5-M) and take out the brush holder assembly (3-M). If the carbon brush is worn out replace the complete assembly (3-M).
5. Remove the four motor cover screws (2-M) and lift the motor cover (1).
6. Remove field and armature and replace as required.
7. Reassemble in reverse order making sure the field springs (10-M), the ground washer (16-M) and the ground lead are in correct position.

## IVIE Enterprises

[www.ivie-ent.com](http://www.ivie-ent.com) Ph:(918)254-5161 or (888)262-5161 Fax:(918)250-4807

**CLARKE TECHNOLOGY**  
**530 Upright Vacuum**  
**External Parts 7/99**

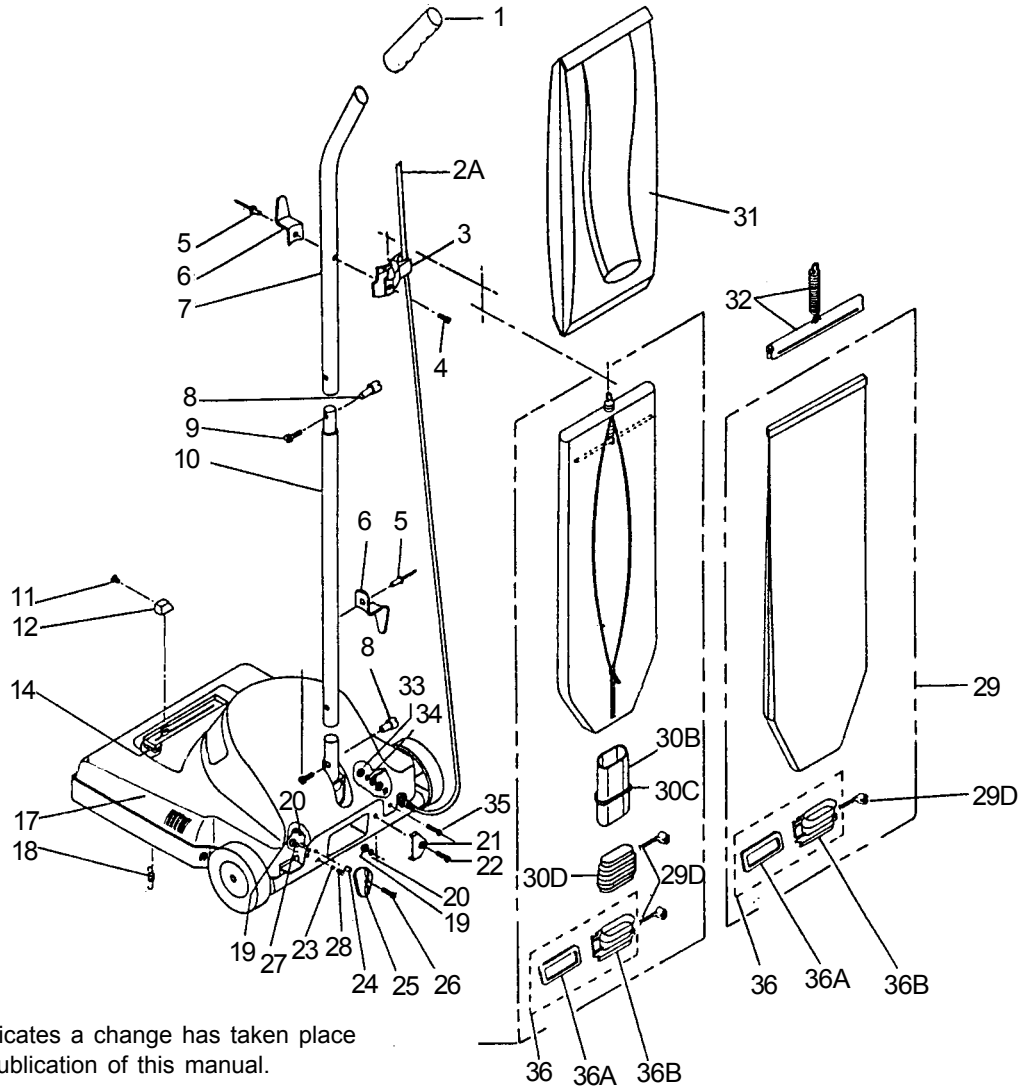

NOTE: □ indicates a change has taken place since last publication of this manual.

Ref.	Part No.	Description	Qty	Ref.	Part No.	Description	Qty
1	50037A	Handle Grip	1	23	50058A	Ball	1
2A	50038A	Line Cord Assembly, 3W/120v	1	24	50059A	Bag Knob Spacer	1
2A	52092A □	Line cord Assembly, 3W/230v	1	25	50060A	Bag Knob	1
3	50039A	Cord Retainer	1	26	85383A	Screw, #10-32 x 3/4	1
4	962731	Screw Type "A" #8 x 1/2	1	27	50061A	Screw, 6 x 5 <sup>5</sup> / <sub>16</sub>	1
5	50040A	Pop Rivet 5/32 x 1/4	2	28	50062A	Knob Spring	1
6	50041A	Cord Hook	2	29	50064A	Permanent Cloth Bag Asm.	1
7	50042A	Upper Handle	1	29D	50067A	Plastic Strap	2
8	50043A	Handle Nut	2	30	50069A	Zipper Bag Assembly	1
9	85361A □	Screw, #10-32 X 1	2	30B	50072A	Paper Bag Connector	1
10	50044A	Lower Handle	1	30C	50073A	Spring Paper Bag	1
11	962606 □	Screw, 6 x 3/8	1	30D	50074A	Zipper Bag Hose	1
12	50045A	Wheel Height Knob	1	31	660683 □	Paper Bag	1
14	50047A	Felt	1	32	50076A	Clip Bag	1
17	50054A	Hood, without Lens	1	33	920108	Hexagonal Nut 8-32	2
18	50055A	Hood Spring	2	34	50077A	Star Washer	2
19	920224 □	Nut #10-32	2	35	85303A	Screw, 8-32 x 3/8	1
20	50056A	Star Washer, #10 x .204	2	36	50078A	Bag Coupling Gasket Asm.	1
21	50057A	Bag Support	1	36A	50079A	Bag Coupling Gasket	1
22	85307A	Screw, #10-32 x 5/8	1	36B	50080A	Bag Coupling	1

CLARKE TECHNOLOGY  
530 Upright Vacuum  
Internal Parts 7/99

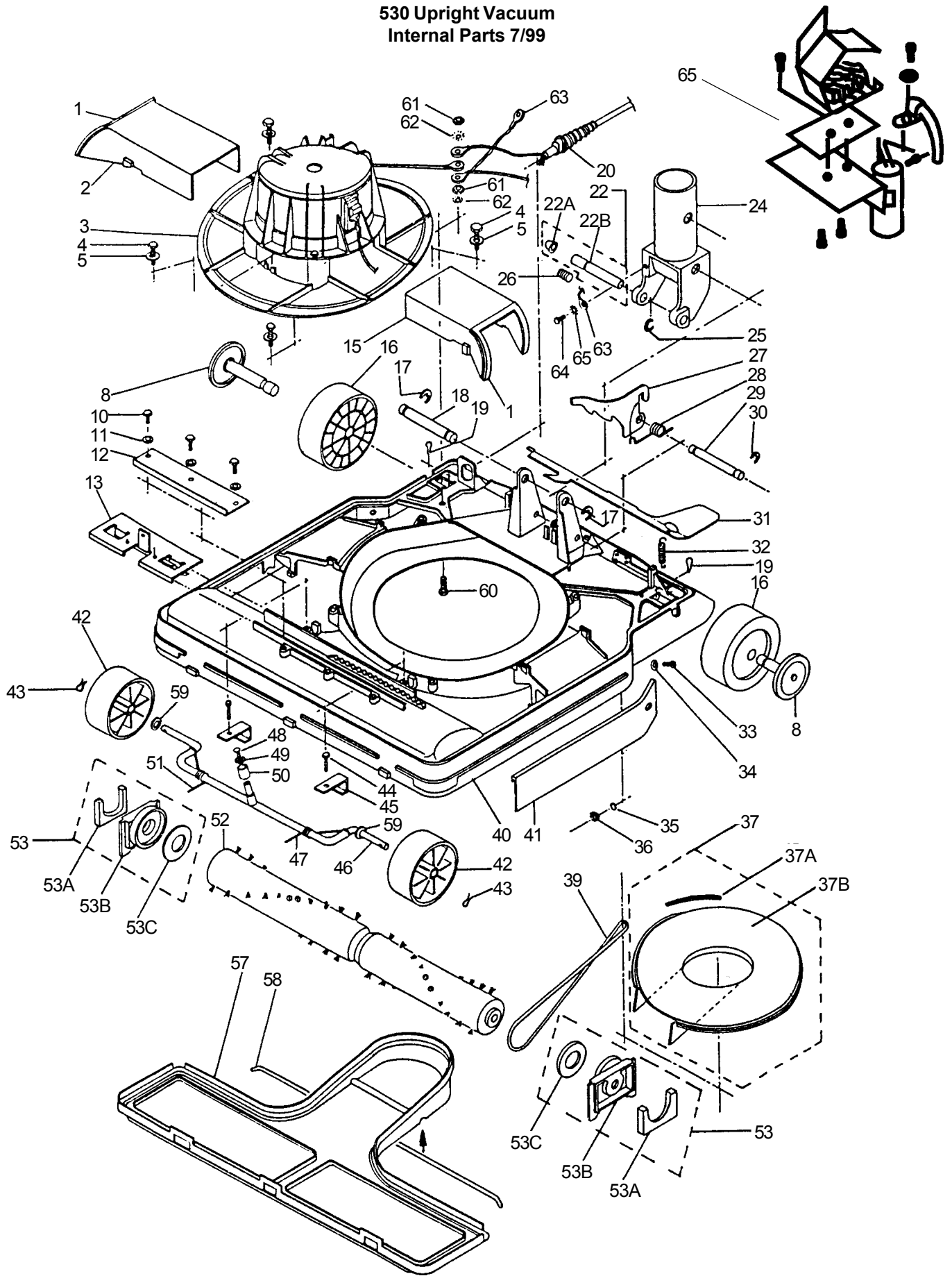

**IVIE Enterprises**

[www.ivie-ent.com](http://www.ivie-ent.com)

Ph:(918)254-5161 or (888)262-5161 Fax:(918)250-4807

**CLARKE TECHNOLOGY**  
**530 Upright Vacuum**  
**Internal Parts 7/99**

Ref.	Part No.	Description	Qty.
1	50081A	Air Duct Gasket	1
2	50082A	Right Air Duct	1
3	50084A	Motor Assembly, 120v	1
3	50085A	Motor Assembly, 230v	1
4	962027	Screw, #8-32 x 1/2	4
5	50087A	Flat Washer .208 x 1/2	4
8	50090A	Rear Wheel Hub Asm.	2
10	85313C	Screw, #6-32 x 3/8	3
11	50091A	Flat Washer .208 x 1/2	3
12	50092A	Plate Cam Guide	1
13	50093A	Can Spring Asm.	1
15	50094A	Left Air Duct	1
16	50095A	Rear Wheel	2
17	50096A	Washer 15/16	2
18	50097A	Socket Bolt	1
19	50098A	Retainer Clip	2
22	50099A	Switch Actuator Asm.	1
22A	50171A	Switch Actuator	1
22B	50172A	Switch Bolt	1
24	50173A	Tube Socket	1
25	50174A	Washer, .207 x .507	1
26	50175A	Spring	1
27	50176A	Handle Cam	1
28	50177A	Cam Spring	1
29	50178A	Cam Bolt	1
30	50179A	Washer 3-16	2
31	50180A	Handle Release Pedal	1
32	50181A	Spring	1
33	962350	Screw, #10-32 x 1/2	2
34	50182A	Flat Washer .200x .624	2
35	50183A	Star Washer #10 x .204	2
36	920224	Nut 10-32	2
37	50184A	Fan Cover With Gasket	2
37A	50185A	Fan Cover Gasket	
37B	50186A	Fan Cover	1
39	903340	Brush Roll Belt	1
40	50188A	Chassis	1
41	50189A	Bumper	1
42	50190A	Front Wheel	2
43	50191A	Cotter Pin	2
44	962027	Screw, #8-32 x 1/2	3
45	50192A	Front Axle Retainer	2
46	50193A	Front Axle Assembly	1
47	50194A	Front Axle Spring	1
48	50195A	Type B Rivet	1
49	50196A	Flat Washer, .171 x .500	1
50	50197A	Axle Bushing	1
51	50198A	Front Axle Spring	1
52	50199A	Brush Roll Assembly	1
53	50210A	Bearing Support Assembly	1
53A	50211A	Bearing Support Gasket	2
53B	50212A	Bearing Support	2
53C	50213A	Bearing Support Felt	2
57	50214A	Bottom Plate With Gasket	1
58	50215A	Bottom Plate Retainer	1
59	50216A	Flat Washer, .315 x .627	2
60	962992	Screw, #8.32 x 5/8	1
61	920108	Hexagonal Nut 8-32	2
62	50217A	Star Washer, 10 x .204	3
63	50218A	Ground Lead	1
64	962606	Screw, #6 x 5/16	1
65	52091A	Radio Supressor (230V)	1

**NOTE:** □ indicates a change has taken place since last publication of this manual.

**CLARKE TECHNOLOGY**  
**530 Upright Vacuum**  
**Motor Assembly 7/99**

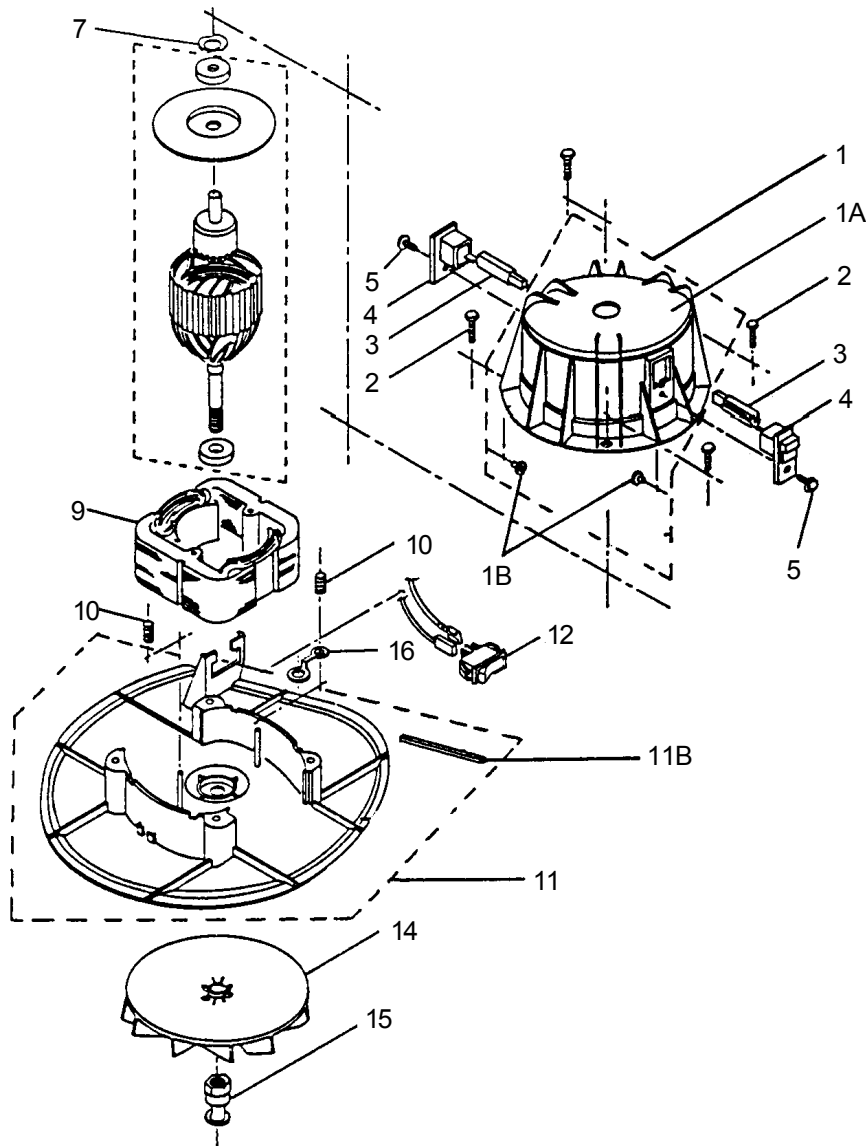

**NOTE:** □ indicates a change has taken place since last publication of this manual.

Ref.	Part No.	Description	Qty
1	50219A	Motor Cover Assembly	1
1A	50220A	Motor Cover	1
1B	50221A	Nut #8-32	2
2	962731	Screw, 8 x 1/2	4
3	50222A	Brush Holder Assembly	2
4	50223A	Brush Holder Support	2
5	85303A	Screw #8-32 x 3/8	2
7	50224A	Washer .850 x .017	1
8	52088A □	Armature Assembly 120v	1
8	52089A □	Armature Assembly 230v	1

Ref.	Part No.	Description	Qty
9	50226A	Field Assembly 120v	1
9	52090A □	Field Assembly 230v	1
10	50228A	Spring	2
11	50229A	Motor Base with Gasket	1
11B	50231A	Motor Base Gasket	
12	50232A	Rocker Switch	1
14	50233A	Fan	1
15	50234A	Belt Pulley Nut	1
16	50235A	Ground Washer	1

## TROUBLE SHOOTING GUIDE

PROBLEM	POSSIBLE CAUSE	SOLUTION
Motor does not run.	<ol style="list-style-type: none"> <li>1) Not firmly plugged in.</li> <li>2) Bad On-Off switch.</li> <li>3) Line open.</li> <li>4) Motor open.</li> <li>5) Fan locked by material.</li> </ol>	<ol style="list-style-type: none"> <li>1) Check attachment plug.</li> <li>2) Replace switch.</li> <li>3) Replace cord.</li> <li>4) Check motor and wiring.</li> <li>5) Remove obstruction.</li> </ol>
Motor runs but cleaner does not pick up.	<ol style="list-style-type: none"> <li>1) Belt broken.</li> <li>2) Blocked air system.</li> <li>3) Fan broken.</li> <li>4) Worn brush roll.</li> <li>5) Motor slow.</li> <li>6) Bag full.</li> </ol>	<ol style="list-style-type: none"> <li>1) Replace belt.</li> <li>2) Clean obstruction.</li> <li>3) Replace fan.</li> <li>4) Replace brush roll.</li> <li>5) Check carbon brushes.</li> <li>6) Empty bag (or change paper bag).</li> </ol>
Motor runs erratically.	<ol style="list-style-type: none"> <li>1) Worn carbon brushes.</li> <li>2) Defective armature.</li> <li>3) Bad electrical connection.</li> <li>4) Defective On-Off switch.</li> </ol>	<ol style="list-style-type: none"> <li>1) Replace brushes.</li> <li>2) Check spark, replace armature.</li> <li>3) Check wiring.</li> <li>4) Replace switch.</li> </ol>
Brush roll vibrates.	<ol style="list-style-type: none"> <li>1) Ball bearing worn out.</li> <li>2) Ball bearing holder damaged.</li> </ol>	<ol style="list-style-type: none"> <li>1) Replace brush roll.</li> <li>2) Replace ball bearing holder.</li> </ol>

**CLARKE TECHNOLOGY**  
**530 Upright Vacuum**  
**Wiring Diagram 8/98**

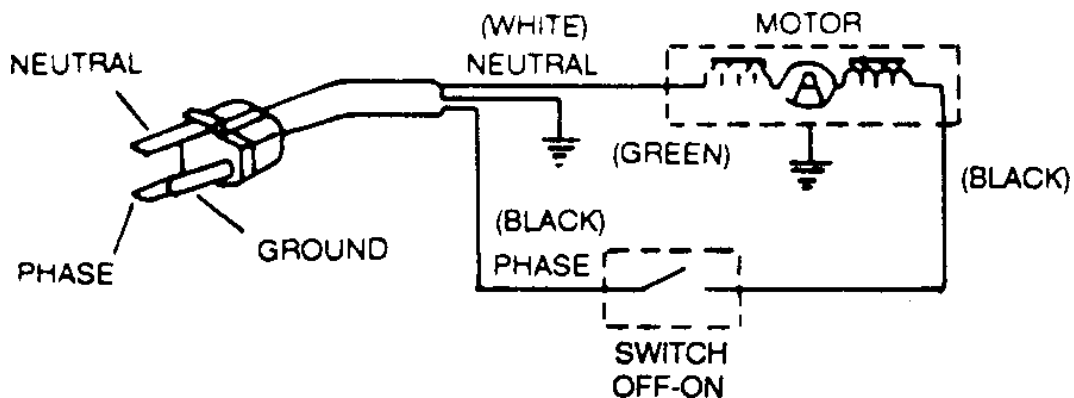

**IVIE Enterprises**

[www.ivie-ent.com](http://www.ivie-ent.com) Ph:(918)254-5161 or (888)262-5161 Fax:(918)250-4807

**CLARKE TECHNOLOGY**  
**530cc Upright Vacuum**  
**Assembly Drawing and Parts List 7/99**

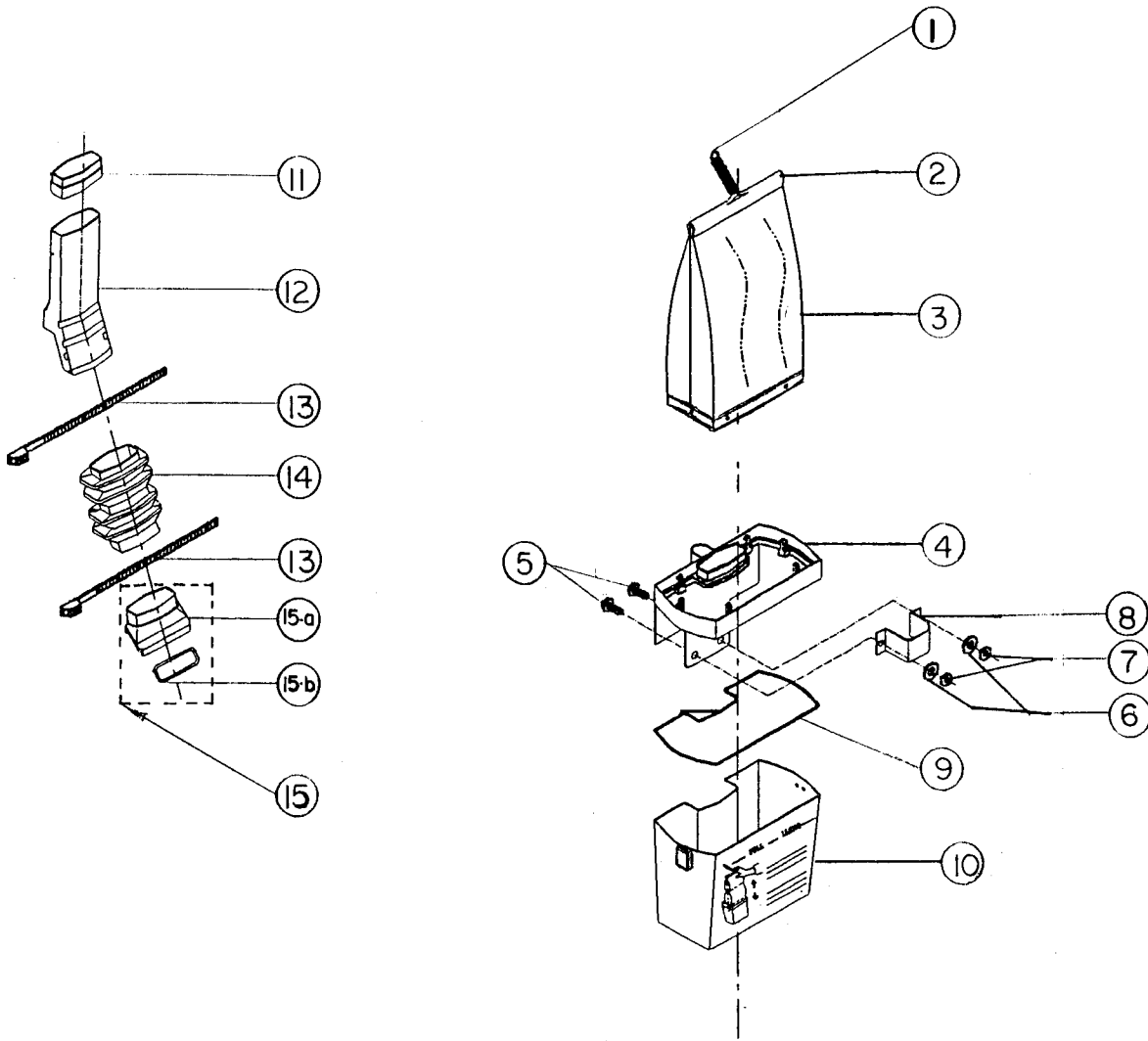

Ref.	Part No.	Description	Qty
1	50807A	Bag Spring	1
2	50808A	Bag Clip	1
3	50809A	Bag Assembly	1
4	50810A	Cup Frame	1
5	85303A	Screw, 8-32 x 3/8	2
6	50087A	Flat Washer	2
7	50221A	Hex Nut, 8-32	2
8	50811A	Clamp	1
9	50812A	Cup Gasket	1
10	50813A	Cup Assembly	1
11	50814A	Upper Hose Seal	1
12	50815A	Exhaust Hose	1
13	619221	Cable Tie	2
14	50816A	Dust Cup Hose	1
15	50078A	Bag Coupling Gasket Asm.	1
15a	50080A	Bag Coupling	1
15b	50079A	Bag Coupling Gasket	1