

IVIE Enterprises

www.ivie-ent.com Ph:(918)254-5161 or (888)262-5161 Fax:(918)250-4807

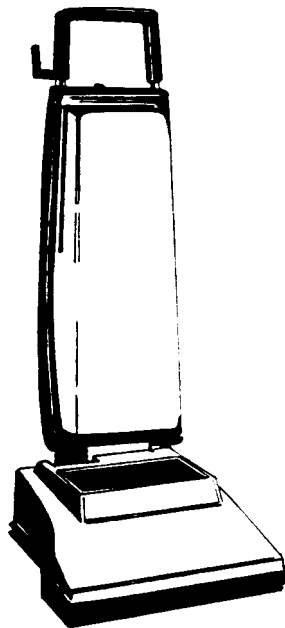

**Service
Manual**



**Model 577
Carpetmaster**

READ THIS BOOK

This book has important information for the use and safe operation of this machine. Failure to read this book prior to operating or attempting any service or maintenance procedure to your ALTO machine could result in injury to you or to other personnel; damage to the machine or to other property could occur as well. You must have training in the operation of this machine before using it. If you or your operator(s) cannot read English, have this manual explained fully before attempting to operate this machine.

Si Ud. o sus operadores no pueden leer el Inglés, se hagan explicar este manual completamente antes de tratar el manejo o servicio de esta máquina.

All directions given in this book are as seen from the operator's position at the rear of the machine.

For new books write to: ALTO U.S. Inc., 2100 Highway 265, Springdale, Arkansas 72764.

CLARKE TECHNOLOGY
Model 577 Upright Vacuum
Wiring Diagram & Schematic 8/98

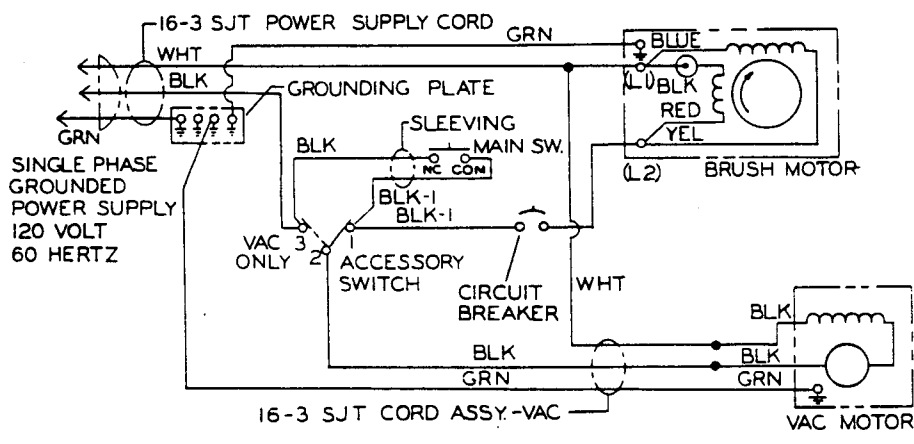
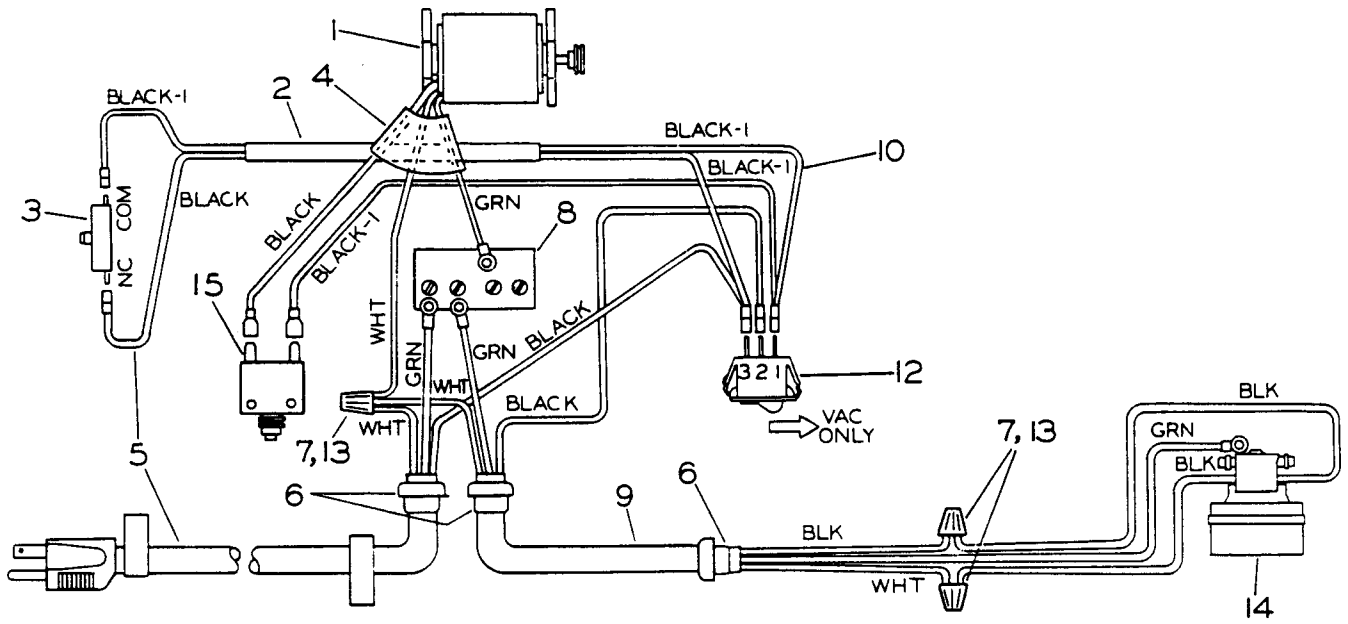

Ref	Part No.	Description	Qty	Ref	Part No.	Description	Qty
1	44606A	Motor Asm. - Brush ¼HP 120V	1	10	912294	Lead Asm.	1
	44602A	Motor Asm. - Brush ¼HP 220V	1	11			
2	48500A	Tubing	1	12	912262	Switch - Accessory	1
3	911562	Switch (Main)	1	13	990716	Tape - Electrical	1
4	609407	Tubing	1	14	44900A	Motor - Vac 120V	1
5 u	42186B	Cord Asm. (Power Supply)	1		44901A	Motor - Vac 220V	1
6	657501	Strain Relief	3	15	912263	Circuit Breaker, 120V	1
7	911413	Wire Nut	3		912270	Circuit Breaker, 220V	1
8	606440	Plate, Grounding	1				
9 u	41954A	Cord Asm. (Vac Motor)	1				

NOTE:
 u indicates a change has been made since last publication of this manual.

CAUTION: Repairs by qualified personnel only.
ARHTUNG: Reparaturen nur durch facharbeiter.
PRECAUCION: Reparaturen par personnel specialise seulement.
PRECAUCION: Unicamente personal calificado deberian hacer reparaciones.

CLARKE TECHNOLOGY
 Model 577 Upright Vacuum
 Drawing Upper Half 3/00

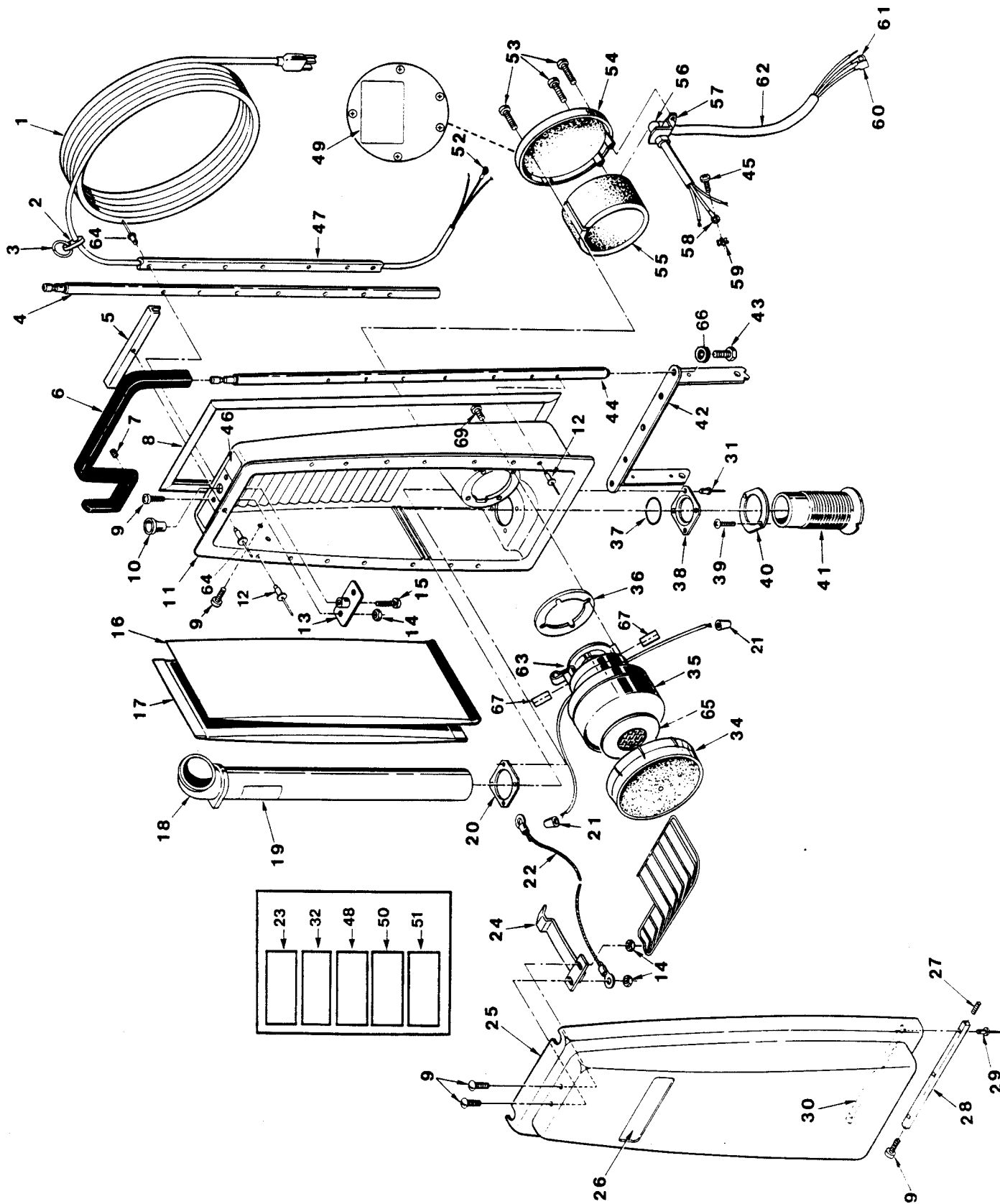

CLARKE TECHNOLOGY
Model 577 Upright Vacuum
Parts List Upper Half 3/00

Ref #	Part No.	Description	Qty
1	42186B	Cord Assembly, Power	1
2	604040	Holder, handle cord	1
3	607340	Ring Split	1
4	609041	Tube Asm., Handle RH	1
5	33500A	Filler, Tank Flange	1
6	603940	Handle	1
7	962965	Screw, 10-24 x ⁵ / ₁₆ Set	2
8	603443	Gasket, Tank	1
9 ◆	962968	Screw 10-24 x ½ Pan Hd	7
10	875072	Knob	1
11	38902B	Tank, Rear	1
12	930113	Rivet, Pop ⅛ Dia. Open End	14
13	602440	Catch, Latch	1
14	920200	Nut, 10-24 Hex Hd.	4
15	86100A	Screw 10-24 x 1 ³ / ₈ Soc. Hd.	1
16	60700A	Bag, Cloth	1
17	600641	Bag, Paper (Pkg. of 6)	1
18	39300A	Tube, Standpipe	1
19	625184	Label	1
20	623380	Flange, Backup	1
21	911413	Nut, Wire	2
22	602442	Cord, Asm., Nylon	1
23	215104	Label, Warning	1
24	65500A	Latch, Tank	1
25	30003A	Tank, Front	1
26 ◆	77378A	Label, Clarke Technology	1
27	925546	Pin, ³ / ₁₆ x ½ Roll	1
28	66100A	Pivot, Front Tank	1
29	930120	Rivet, ⅛ Dia Pop	3
30	601340	Backup, Tank Lower	1
31	930077	Rivet, ⅛ x .482 Lg. Cl. End	4
32	73273A	Label, Warning, Electric Shock	1
33	67303A	Shelf, Bag Support	1
34	623382	Filter, Vac Can	1
35	44900A	Motor, Vacuum (120V)	1
	44901A	Motor, Vacuum (220V)	1

Ref #	Part No.	Description	Qty
36	623443	Gasket, Vacuum Motor	1
37	627680	Seal, O'Ring	1
38	603341	Flange, Retainer	1
39 ◆	85517A	Screw, 10-24 x ½	2
40	602041	Clamp, Hose	1
41	604140	Hose, Standpipe	1
42	61200A	Bracket, Asm., Pivot	1
43	85810A	Screw ⁵ / ₁₆ -18 x ⁵ / ₈	2
44	609040	Tube, Asm., Handle LH	1
45 ◆	962546	Screw 10-24 x ½ Rd. Hd.	2
46	605147	Label, Tank Latch	1
47	607245	Retainer, Cord	1
48	705134	Label, Warning (Canada)	1
49	805151	Label, Exhaust Baffle	1
50	215103	Label, Caution	1
51	215110	Label, Caution, Spanish	1
52	911926	Terminal, Clip #6	1
53	962970	Screw 10-16 x 1¼	5
54	60004A	Baffle, Asm., Exhaust	1
55	37000A	Pad, Noise	1
56	657501	Strain, Relief	1
57	600854	Bracket, Bushing	1
58	912064	Terminal Clip, #10	1
59	980603	Washer, #SH 1110	1
60	911262	Terminal, Female	1
61	911927	Clip, Terminal	1
62	41954A	Cord Asm., Vac Motor	1
63	872102	Clip, ⁵ / ₁₆ Dia. Nylon	1
64	930108	Rivet, ⅛ Diameter Lg. Fl.	8
65	603642	Guard, Vac Motor Fan	1
66	980652	Washer, ⁵ / ₁₆ Lock	2
67	51419A	Brush, Carton (2 Pack)	1
68	962161	Screw, 10-24 x ³ / ₈	1
69 ◆	962900	Screw, 10-16 x ⁵ / ₈	4

NOTE: ◆ indicates a change has been made since last publication of this manual.

IVIE Enterprises
www.ivie-ent.com Ph:(918)254-5161 or (888)262-5161 Fax:(918)250-4807

CLARKE TECHNOLOGY
 Model 577 Upright Vacuum
 Drawing Lower Half 3/00

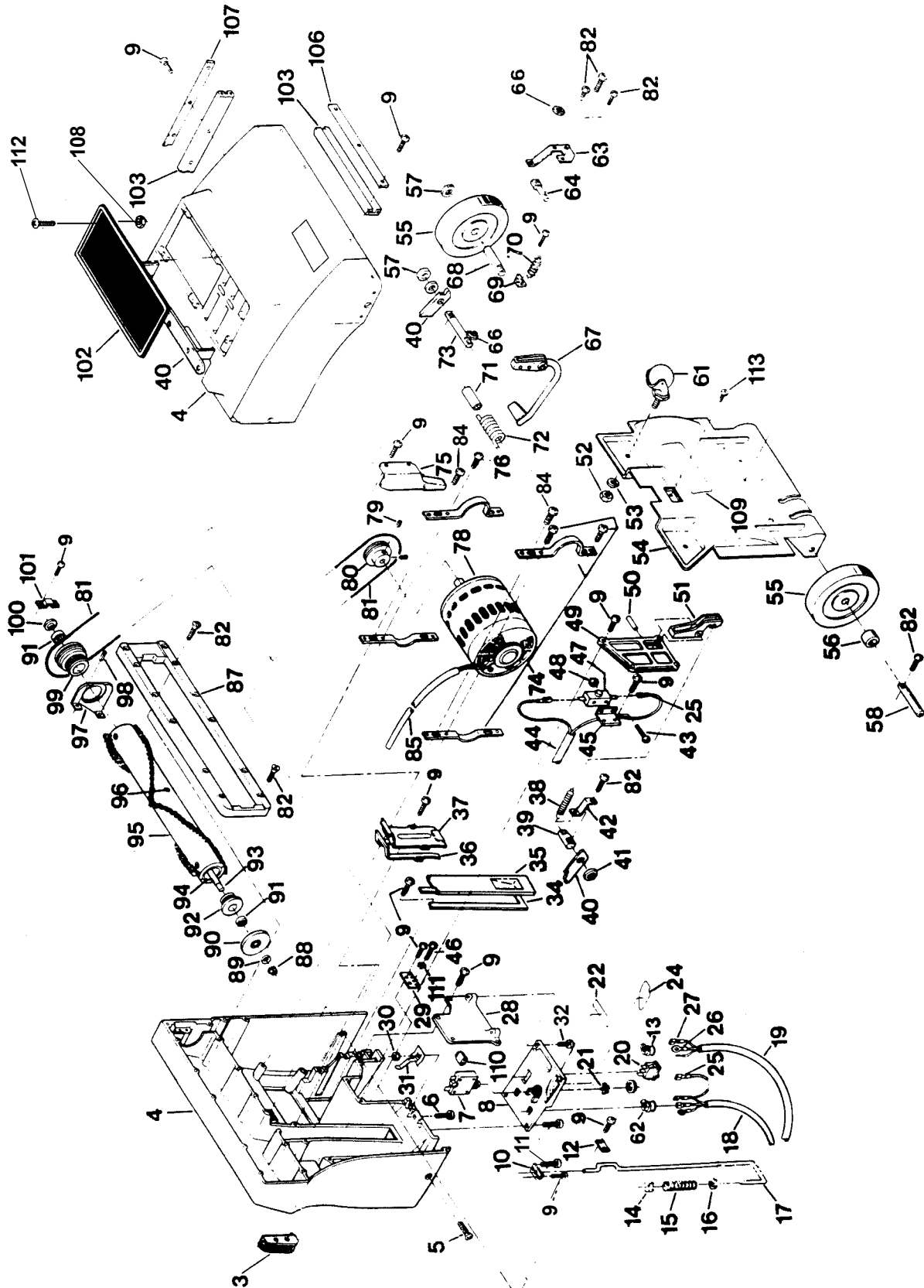

**CLARKE TECHNOLOGY Model 577 Upright Vacuum
Parts List Lower Half 3/00**

Ref#	Part No.	Description	Qty	Ref#	Part No.	Description	Qty
1				58	607041	Pivot, Wheel Right Hand	1
2				59	NI	Plate, Model & Serial (120V)	1
3	617522	Roller Asm. - Side	1		NI	Plate, Model & Serial (220V)	1
4	24526B	Frame - Main	1	60			
5	962968	Screw - #10-24 x 1/2 Pn	2	61	629770	Caster	2
6 ♦	962041	Screw - #10-24 x 7/16 Pan	2	62	46712A	Strain Relief	1
7	912263	Circuit Breaker 120V	1	63	61007A	Brace, Lever Assembly	1
	912270	Circuit Breaker 220V	1	64	607741	Shaft, Lever Release	1
8	32334B	Cover, Electrical	1	65			
9	85517A	Screw 10-24 x 1/2	38	66	920110	Nut, ESNA	2
10 ♦	61196B	Plate, Cam Rod	1	67	16701A	Lever, Assembly, Release	1
11 ♦	962954	Screw #8-18 x 1/2	1	68	607040	Pivot, Wheel Left Hand	1
12	612050	Clamp	1	69	610853	Bracket, Spring	1
13	657501	Relief, Strain	2	70	608340	Spring	1
14	608245	Spacer, Cam Rod	1	71	621181	Bushing, Pivot	1
15	628382	Spring, Rod Return	1	72	628380	Spring	1
16	980646	Washer 1/4 Plain	1	73	66140A	Pivot, Tank Assembly	1
17	67100A	Rod, Cam	1	74	620891	Bracket, Assembly, Motor	2
18	42186B	Cord Assembly, Power	1	75	603641	Guard, Belt	1
19	41954A	Cord Asm., Vac Motor	1	76	962027	Screw 8-32 x 1/2 Rd. Hd.	4
20	912262	Switch	1	77			
21	980407	Washer, Shakeproof	1	78	44606A	Motor, Brush Drive (120V)	1
22	605143	Label, Rear Cover	1		44602A	Motor, Brush Drive (220V)	1
23				79	962165	Screw 10-24 x 3/16 St	2
24	605145	Label, Brush Adjustment	1	80	616950	Pulley, Driver	1
25	911208	Terminal, Clip	1	81	903042	Belt	1
26	911927	Terminal, Ring Tongue	1	82 ♦	85603A	Screw 10-24 x 1 1/4	18
27	911262	Terminal, Clip	1	83			
28	602341	Cover, Bottom Electrical	1	84 ♦	962677	Screw, 10-24 x 3/4	4
29	606440	Plate, Grounding	1	85	609047	Tubing, Electrical	1
30	920200	Nut #10-24 Hex	1	86			
31	602040	Clamp, Tunnel	1	87	38504A	Shoe	1
32 ♦	962957	Screw 10-16 x 1/2	1	88	621182	Bushing, Shaft	1
33				89	980442	Washer, Wave	1
34	603441	Gasket, Tray	1	90	623681	Guard, Thread	1
35	68300A	Tray Asm., Cleanout	1	91	902648	Bearing	2
36	603440	Gasket, Inlet Cover	1	92	626671	Plate, End	1
37	602345	Cover, Inlet	1	93	627770	Shaft, Brush	1
38	628383	Spring	1	94	629070	Tube, Brush	1
39	607044	Pivot, Tank Assembly	1	95	620970	Brush, Half (Set of 2)	1
40	61200A	Bracket Assembly, Pivot	1	96	962821	Screw 8 x 5/8 Flat Head	6
41	980091	Washer, Thrust	1	97	607640	Seal, Brush End	1
42	600842	Bracket, Spring Mounting	1	98	925589	Pin 1/8 x 1/2 Roll	2
43	962212	Screw 6-32 x 7/8 Pn	2	99	606943	Pulley, Driven	1
44	48500A	Tubing, Electrical	1	100	623680	Guard, Thread	1
45	600841	Bracket, Switch Mounting	1	101	607246	Retainer, Brush Shaft	1
46	962979	Screw, 6-32 x 1/2 Pan	3	102 ♦	60019A	Plate, Label	1
47	911562	Switch, cherry	1	103	31200A	Bumper	1
48	920056	Nut 6-32 ESNA	2	104			
49	602342	Cover, Switch	1	105			
50 ♦	925062	Pin, 3/16 Spiral	1	106	607240	Retainer, Bumper Front	1
51	605140	Lever, Switch	1	107	607247	Retainer, Bumper Left Hand	1
52	920256	Nut 5/16 -18 Hex	2	108 ♦	920296	Nut 10-24 Elastic Stop	6
53	980652	Washer 5/16 Lock	2	109	605146	Label, Bottom Cover	1
54	61181A	Bracket, Cover & Caster	1	110	672412	Connector, Wire (220 volt)	1
55	629780	Wheel	2	111	980607	Washer #1106 Shakeproof	4
56	38700A	Spacer, Wheel	1	112 ♦	85381A	Screw, 10-24 x 3/4	6
57	38701A	Spacer, Wheel	4	113 ♦	962987	Screw 10-24 x 3/8 Pan	1

NOTE:
♦ indicates a change has taken place since last publication of this manual.