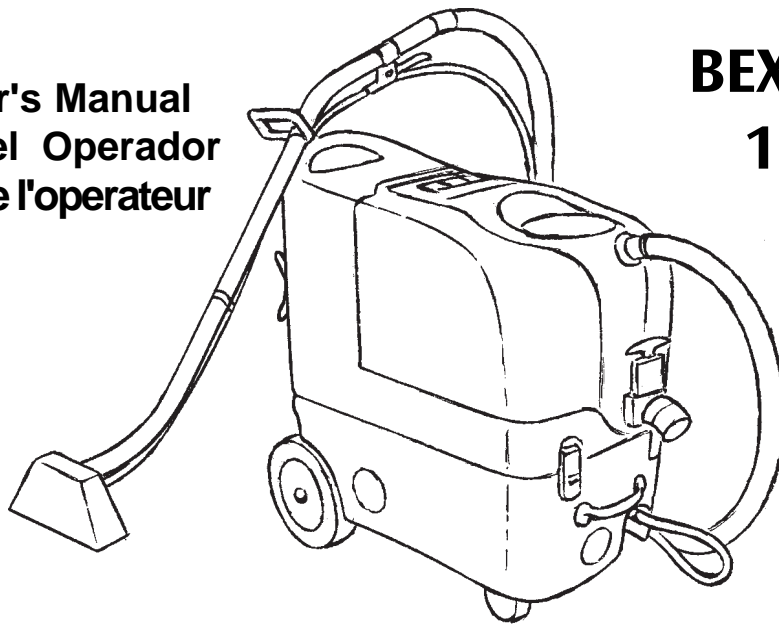

Clarke®

**Operator's Manual
Manual del Operador
Manuel de l'opérateur**



**BEXT®-100, 100H,
150H, 300HV
120V
Extractor's**

READ THIS BOOK

This book has important information for the use and safe operation of this machine. Failure to read this book prior to operating or attempting any service or maintenance procedure to your Clarke machine could result in injury to you or to other personnel; damage to the machine or to other property could occur as well. You must have training in the operation of this machine before using it. If your operator(s) cannot read English, have this manual explained fully before attempting to operate this machine.

Si Ud. o sus operadores no pueden leer el Inglés, se hagan explicar este manual completamente antes de tratar el manejo o servicio de esta máquina.

All directions given in this book are as seen from the operator's position at the rear of the machine.

For new books write to: Clarke®, 2100 Highway 265, Springdale, Arkansas 72764.

CONTENTS OF THIS BOOK

| | |
|--|----|
| Operator Safety Instructions | 5 |
| Introduction and Machine Specifications | 6 |
| Controls and Machine Features | 12 |
| How to Prepare the Machine for Operation | 14 |
| Set-Up | 14 |
| BEXT®-100 Control Panel | 16 |
| BEXT®-100H Control Panel | 16 |
| BEXT®-150H Control Panel | 18 |
| BEXT®-300HV Control Panel | 18 |
| | |
| Instructions for Connection to the Power Supply - 120V | |
| Extension Cords - 120V | 20 |
| | |
| Machine Operating Instructions | 22 |
| How to Clean an Area of Carpet | 22 |
| How To clean a Larger Area of Carpet | 22 |
| | |
| Maintenance | 24 |
| After Each Use of the Machine | 24 |
| How to Prevent Damage from Freezing Temperatures | 26 |
| The Pump and Vacuum Motor | 26 |
| How To Check The Commutator and The Carbon Brushes | 28 |
| | |
| How to Correct Problems in the Machine | 30 |
| | |
| BEXT®-100 Assembly Drawing | 34 |
| Parts List | 35 |
| BEXT®-100H Assembly Drawing | 36 |
| Parts List | 37 |
| BEXT®-150H Assembly Drawing | 38 |
| Parts List | 39 |
| BEXT®-300HV Assembly Drawing | 40 |
| Parts List | 41 |
| BEXT®-100 Accessories | 42 |
| BEXT®-100H Accessories | 43 |
| BEXT®-150H Accessories | 44 |
| BEXT®-300HV Accessories | 45 |
| | |
| Control Panel Wiring Diagram | 46 |
| Electrical Schematic 120V | 47 |

OPERATOR SAFETY INSTRUCTIONS



WARNING





AVERTISSEMENT





ADVERTENCIA


For the safe operation of this machine, read and understand all warnings and cautions.


 **DANGER** means: Severe bodily injury or death can occur to you or other personnel if the **DANGER** statements found on your machine or in your Owner's Manual are ignored or are not adhered to. Read and observe all **DANGER** statements found in your Owner's Manual and on your machine.


 **WARNING** means: Injury can occur to you or to other personnel if the **WARNING** statements found on your machine or in your Owner's Manual are ignored or are not adhered to. Read and observe all **WARNING** statements found in your Owner's Manual and on your machine.


 **CAUTION** means: Damage can occur to the machine or to other property if the **CAUTION** statements found on your machine or in your Owner's Manual are ignored or not adhered to. Read and observe all **CAUTION** statements found in your Owner's Manual and on your machine.

 **DANGER:** Machines can cause an explosion when operated near flammable materials and vapors. Do not use this machine with or near fuels, grain dust, solvents, thinners, or other flammable materials.

 **DANGER:** Do not immerse. To reduce the risk of an electric shock, use only on a carpet that has been moistened by a cleaning process. Protect the machine from rain. Keep the machine in a dry building. Always clean the machine with a clean dry cloth.


 **WARNING:** You must have training in the operation of this machine before using it. **READ THE INSTRUCTION BOOK FIRST.**

 **WARNING:** Always use a three-wire electrical system connected to the electrical ground. For maximum protection against electric shock, use a circuit that is protected by a ground fault circuit interrupter. Consult your electrical contractor.


 **WARNING:** To prevent electric shock, always remove the electrical plug from the electrical outlet before doing any repairs or maintenance to this machine.

 **WARNING:** Do not use this machine as a step or furniture. Injury could occur to the operator.


 **WARNING:** To avoid serious injury, use proper lifting procedures when lifting the machine.

 **WARNING:** Maintenance and repairs must be done by authorized personnel only.

 **WARNING:** Keep all fasteners tight. Keep the adjustments according to specifications.

 **WARNING:** Make sure that all the labels, decals, warnings, cautions and instructions are fastened to the machine. Replace them when necessary by ordering them from Clarke.

 **WARNING:** Do not use water that is hotter than 120°F (40°C).

 **WARNING:** If foam/liquid comes out, stop extracting immediately. Allow vacuum(s) to run until exhaust air is dry.

OPERATOR SAFETY INSTRUCTIONS (CONT.)

⚠ WARNING: Improper discharge of waste water may damage the environment and be illegal. The United States Environmental Protection Agency has established certain regulations regarding discharge of waste water. Also, city and state regulation regarding this discharge may be in effect in your area. Understand and follow the regulations in your area. Be aware of the environmental hazards of chemicals that you dispose.

⚠ CAUTION: To prevent damage to the power cord, do not move this machine over the power cord, instead, lift the power cord over the machine. If the cord supplied is damaged, it must be replaced by the manufacturer, its service agent or a similarly qualified person in order to avoid the hazard.

⚠ CAUTION: To prevent damage to the power cord and hoses, do not use the power cord or hoses to pull the machine.

⚠ CAUTION: To prevent damage to the machine avoid extreme temperatures.

⚠ CAUTION: To prevent damage to the machine do not let pump run dry.

INSPECTION: Carefully unpack and inspect your new Extractor for shipping damage. Each unit is tested and inspected before shipment. Any damage incurred is the responsibility of the carrier, who should be notified immediately.

CLEANING SOLUTIONS: We recommend liquid cleaning chemicals. A pH of 7-9 is strongly recommended to avoid premature pump wear, which would void the warranty.

INTRODUCTION and MACHINE SPECIFICATIONS

- The Model **BEXT®-100, 100H, 150H** or **300HV** is an extractor for cleaning carpet. When used with a floor tool, the machine applies cleaning solution to the carpet and removes the dirty solution and soil from the carpet.
- The extractor has controls to start the pump for the solution and the motor for the vacuum. The floor tools have controls to release the solution.
- The extractor has a bypass pump. The pump runs when switched on, bypassing solution internally to keep pressure even. The extractor starts when the solution lever on the floor tool is activated.

| SPECIFICATIONS | Bext 100 | Bext 100H Bext 100H Detailer | Bext 150H Bext 150H Detailer | Bext 300H |
|----------------------|---|----------------------------------|--------------------------------------|---------------------|
| Part Number | 04156A | 04157A / 04158A | 04147A / 04152A | 04148A |
| Solution Tank | 9 gallon rotationally molded | | 13 gallon rotationally molded | |
| Solutin Pump | 100 psi demand pump | | 150 psi demand pump | 300 psi demand pump |
| Vacuum Motor | 5.7", 3 stage | | (2) - 5.7" 2-stage | 7.2" 3-stage |
| Waterlift | 140" | | 150" | 140" |
| Easy Circuit Locator | N/A | Standard | Standard | Standard |
| On-board Heater | N/A | Standard | Standard | Standard |
| Wand | Double bend twin nozzle polished stainless steel | | | |
| Power Cable | 25 ft. 12-3 hosp. grade plug | (2) 25 ft. 12-3 hosp. grade plug | | |
| Wheels | (2) 8" non-marking & (2) 3" casters | | (2) 10" non-marking & (2) 2" casters | |
| Hose | 15 ft. crushproof vacuum and high pressure solution line | | | |
| Low Moisture System | Standard | | | |
| Float Shut-Off | Standard | | | |
| Weight | 69 lbs. | 75 lbs. | 90 lbs. | 119 lbs. |
| Warranty | Product Lifetime (10 years) on tank and mainframe; 1 year Parts and labor | | | |

NOTE: When using the extractor to clean carpets, follow this procedure:

1. Do not walk on freshly cleaned carpets for at least four hours or until the carpet is dry to touch.
2. Do not remove aluminum or plastic pieces that have been placed under the legs of furniture until the carpet is dry.
3. Do not allow children or pets to crawl or walk around on the damp carpet.
4. Vacuum right after the carpet is dry and then vacuum the carpet once a week as needed.

CONTROLS and MACHINE FEATURES

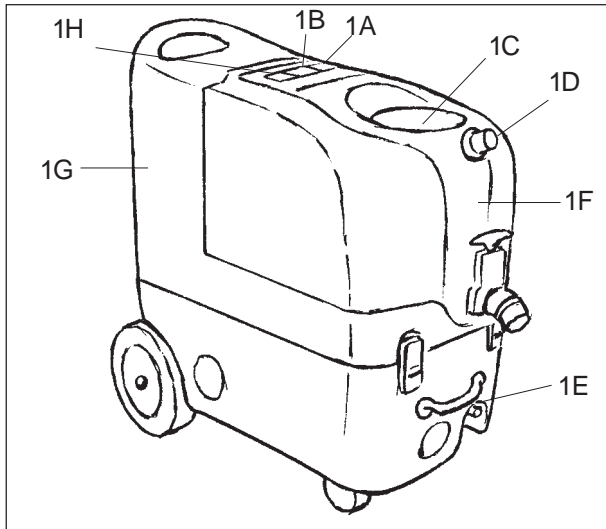


Figure 1

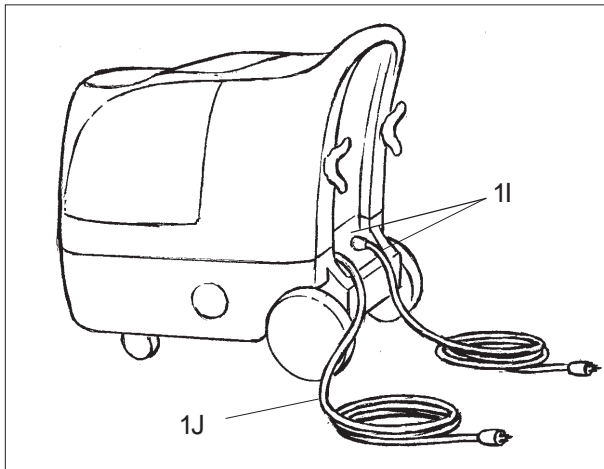


Figure 1

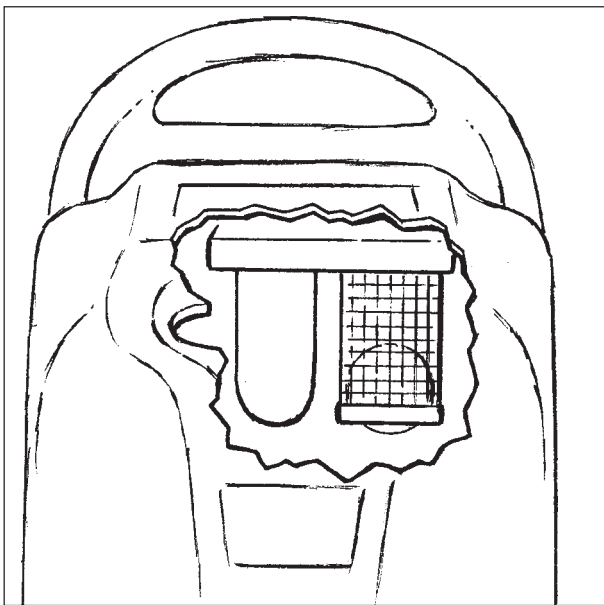


Figure 2

The Vacuum Motor Switches See Figure 1-A

The vacuum motor switches are located on the top of the machine.

The Switch To Activate The Pump See Figure 1-B

The switch to start/stop the pump motor is on the top of the machine. Press the lever on the floor tool to start the solution flow. Release the lever on the floor tool to stop the solution flow.

NOTE: While the BEXT-150 machine is in operation, the pump will shut-off automatically when it reaches full pressure. The pump will automatically turn on when the pressure decreases.

The Float Shut-Off -See Figure 1C

The float shut-off is in the recovery tank. When the liquid raises the float, the air stops moving through the machine.

NOTE: To avoid vacuum motor damage, always inspect the float filter and ball. Verify ball travels easily prior to use of unit. See Figure 2

The Vacuum Hose Connector See figure 1D

The vacuum hose connector is on the front of the unit.

The Solution Hose Connector See Figure 1E

The solution hose connector is on the lower part of the extractor, below the vacuum hose connector.

The Recovery Tank See Figure 1F

The recovery tank is in the top of the machine.

The Solution Tank See Figure 1G

The solution tank is in the top of the machine next to the recovery tank.

Electric Circuit Locator See Figure 1H

This unique, patented "smart system", operated by a solid state circuit, will inform the operator when the two cords are plugged into separate circuits by illuminating the "Locator" indicator light. This helps prevent tripping circuit breakers.

NOTE: Ground plug on the cord is required to allow circuit locator to operate correctly. The system will not function without proper ground.

The Machine Power Cord (Red "H") See Figure 1I

This cord powers all machine functions except the heater.

The Heater Power Cord See Figure 1J

This cord powers heater only.

HOW TO PREPARE THE MACHINE FOR OPERATION

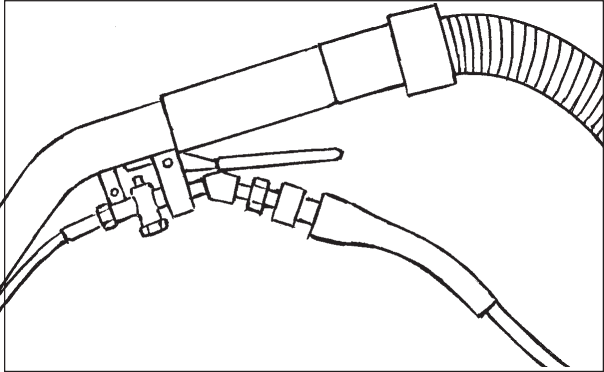


Figure 3A

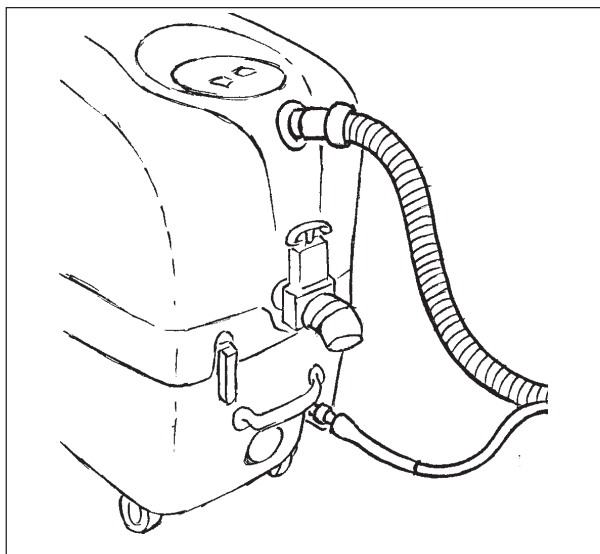


Figure 3B

To prepare the machine for operation, follow this procedure:

1. Connect the vacuum hose to the hose connector on the extractor and to the end of the vacuum tube on the floor tool. See Figure 1 D, E
2. Connect the solution hose to the extractor and the floor tool. To fasten the quick disconnect fitting, slide the knurled collar on the female coupling away from the opening. Push the male coupling into the female coupling. See figure 3 A & B

⚠ WARNING: Do not use water that is hotter than 120°F (48°C).

3. Before moving the extractor onto the carpet, put clean hot water into the solution tank.
4. Add a cleaning chemical, such as Clarkare® Extractor Concentrate, to the hot water. For the correct amount, follow the directions shown on the container.

Set-Up

⚠ WARNING: We recommend that you use liquid cleaning chemicals. Powder can damage machine. Powders can cause build-up in the lines, heater, pump, quick disconnects, etc., all of which would void the warranty on those items. A pH of 7-9 is strongly recommended to avoid damage and premature wear to the pump, which would void the warranty.

Fill the holding tank with clear water and the detergent of your choice. Mix well. Although this machine is designed to supply instant hot water, the addition of warm or hot water to the holding tank is beneficial and will reduce pre-heat times.

- A. Plug in cord #1 (vac and pump), identified by the red "H" on the end of the cord. Attach the priming hose to the machine (on 300 HV only). Turn the pump on and set the switch to the upholstery setting. Run until the pump is fully primed, then turn off the pump. Remove the priming hose and attach the cleaning hoses and tool.
- B. Turn on the pump and spray through the cleaning tool for a few seconds to fill the lines with solution.

BEXT® 100H, 150H & 300HV

- C. Plug in cord #2. The "Locator" light will illuminate when the cords are plugged into separate circuits. Turn the "Heat" switch on; wait two minutes for the heat exchanger to reach operating temperature. You may now begin cleaning. It will take about 10 seconds for the initial heat to reach the wand. The "Mode" light will turn on when the heat exchanger is actively heating. (See Figures 5, 6 and 7)

NOTE: If the "Locator" indicator light does not illuminate when cord #2 is plugged in, then both cords are on the same line. Try other outlets until the light comes on.

⚠ CAUTION: If both cords are plugged into the same circuit breaker, the breaker may blow when operating with the heater on.

5. If the extractor removes an excess amount of foam from the carpet, add a de-foamer such as Clarkare® De-foamer Concentrate to the recovery tank. The amount needed will vary according to the amount of detergent already in the carpet.

CAUTION: To prevent damage, use a water-based de-foamer rather than an oil-based de-foamer.

CAUTION: Do not leave the extractor or other cleaning machines or tools on the carpet when not in use. Cleaning solution in the machines and tools can leak onto the carpet and cause light spots or stains.

NOTE: To order Clarkare® Extractor Concentrate, order part no. 398421. To order Clarkare® Defoamer, order part no. 398420.

For instructions for preparation and operation of your floor tool, read the instruction sheet given with your floor tool.

BEXT®-100 Control Panel

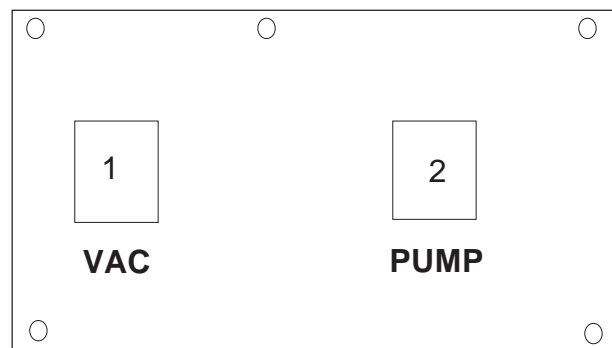


Figure 4

VACUUM SWITCH (1): The vac switches illuminate when turned on.

PUMP SWITCH (2): This switch will illuminate when the pump is on.

BEXT®-100H Control Panel

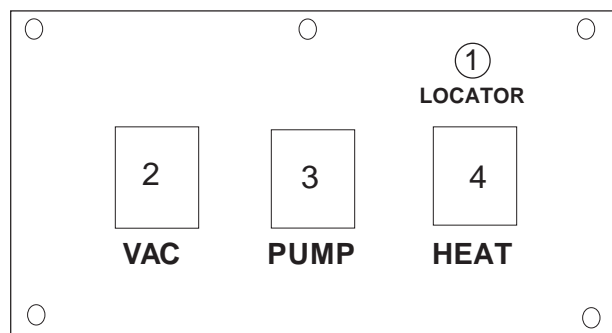


Figure 5

CIRCUIT LOCATOR (1): When this light is on, it indicates that cord #2 is on a separate line from cord #1. Cord #2 supplies voltage to the heater allowing it to heat to the proper temperature range.

VACUUM SWITCH (2): The vacuum switch will illuminate when the vacuum motor is turned on.

PUMP SWITCH (3): This switch will illuminate when the pump is on.

HEAT SWITCH (4): The heat switch will illuminate when it is activated and will turn the heater on.

BEXT®-150 H Control Panel

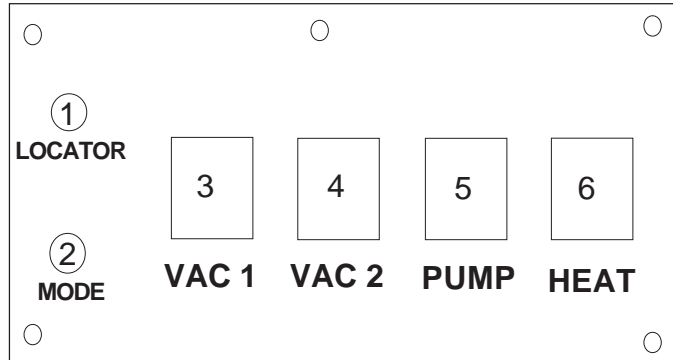


Figure 6

CIRCUIT LOCATOR (1): When this light is on, it indicates that cord #2 is on a separate line from cord #1. Cord #2 supplies voltage to the heater allowing it to heat to the proper temperature range.

HEAT MODE LIGHT (2): This light will only illuminate when the heater is heating and will turn off when it reaches operating temperature.

VACUUM SWITCH (3 & 4): Each switch turns on one vac motor. turn both switches on for maximum lift. The vac switches illuminate when turned on.

PUMP SWITCH (5): This switch will illuminate when the pump is on.

HEAT SWITCH (6) : The heat switch will illuminate when it is activated and will turn the heater on.

BEXT®-300 HV Control Panel

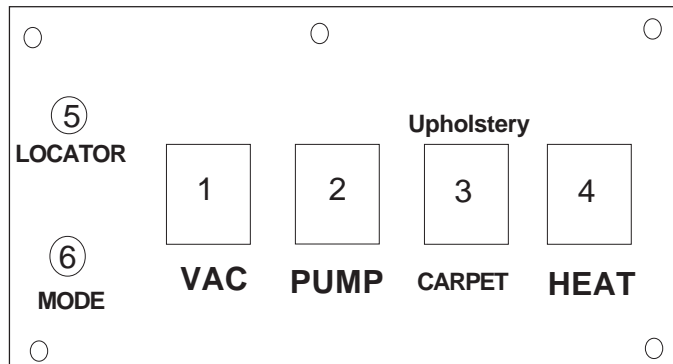


Figure 7

VAC (1) & PUMP (2) SWITCHES: These switches are powered by cord #1 (4" red band). Switches are on when illuminated.

CARPET / UPHOLSTERY SWITCH (3): This switch is also powered by cord #1. The carpet setting (down position) is high pressure (approximately 300 psi). The upholstery setting (up position) is low pressure (approximately 75 psi). NOTE: Switch does not illuminate.

HEAT SWITCH (4): Turning on this switch (switch illuminates when on) turns the heater on.

GREEN CIRCUIT LOCATOR LIGHT (5): When this light is illuminated, it confirms that the machine is on two separate circuits. See previous page for additional information on the circuit locator.

HEAT LIGHT MODE (6) : The light will only illuminate when the heater is heating and will turn off when it reaches operating temperature.

INSTRUCTIONS FOR CONNECTION TO THE POWER SUPPLY AND ELECTRICAL GROUND - 120 V

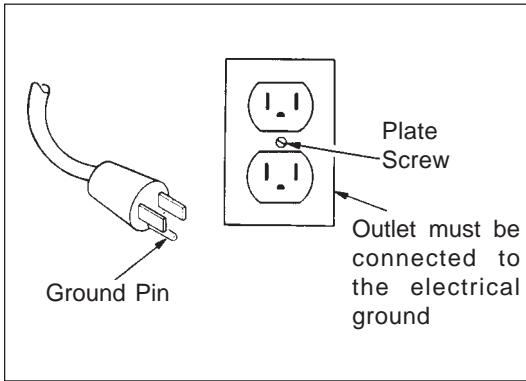


Figure 7

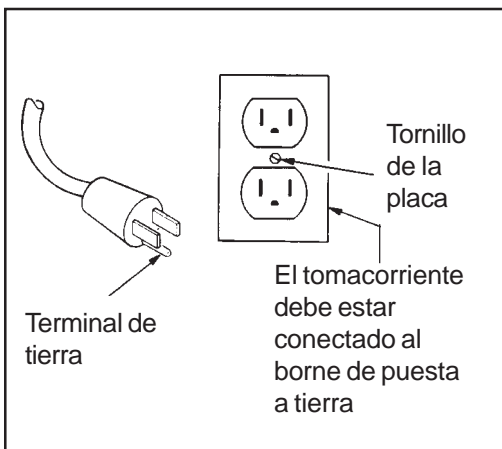


Figura 7

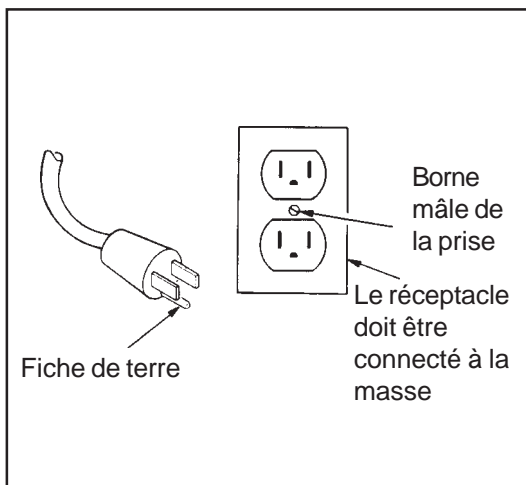


Figure 7

CAUTION: This machine will operate only on an AC frequency and on the specified electrical voltage shown on the nameplate. Make sure you have the correct frequency and voltage before connecting the power cord to an outlet.

This machine must be connected to an electrically grounded circuit in order to protect the operator from electric shock. This machine has an approved power cord with three conductors as well as a plug with three terminals. Connect the plug to a three holed receptacle. For maximum protection against electric shock, use a circuit that is protected by a ground fault circuit interrupter.

This machine uses a 120 volt AC 50/60 cycle electrical circuit. Make sure you have the correct frequency and voltage before connecting the power cord to an outlet. The machine has a plug as shown in Figure 7. If a receptacle connected to the electrical ground as shown in Figure 7 is not available, contact an electrical contractor. Do not use an adapter.

WARNING: To prevent possible electric shock, protect the machine from rain. Keep the machine in a dry building.

WARNING: To prevent possible electric shock, always use a 3-wire electrical system connected to the electrical ground. For maximum protection against electrical shock, use a circuit that is protected by a ground fault circuit interrupter. Consult your electrical contractor.

WARNING: Do not cut, remove, or break the ground pin. If the outlet does not fit the plug, consult your electrical contractor.

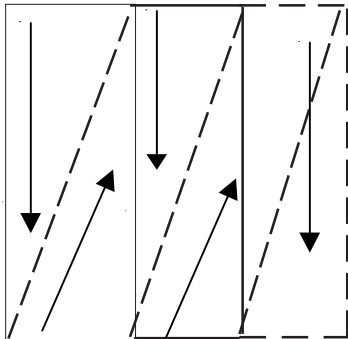
WARNING: If the cords or plugs are worn or damaged in any way, have them replaced by an authorized service person.

Extension Cords

Use only an approved extension cord with three conductors, a plug with three terminals and a three-holed connector body. This machine has a power cord with a wire size of 12 AWG. (AWG stands for American Wire Gauge).

CAUTION: If you use an extension cord, use one that has a minimum wire size of 12 AWG. Be sure your extension cord is no longer than 50 ft. Do not join two extension cords.

Area 1 See figure 8
 Superficie 1. Vea la Figura 8
 Zone 1 Voir figure 8



Vacuum only, after cleaning each area for maximum water removal

Para eliminar la mayor cantidad de agua posible sólo realice la aspiración después de limpiar cada superficie

Aspiration seulement, après nettoyage de chaque zone pour une élimination maximum de l'eau

Figure 8A

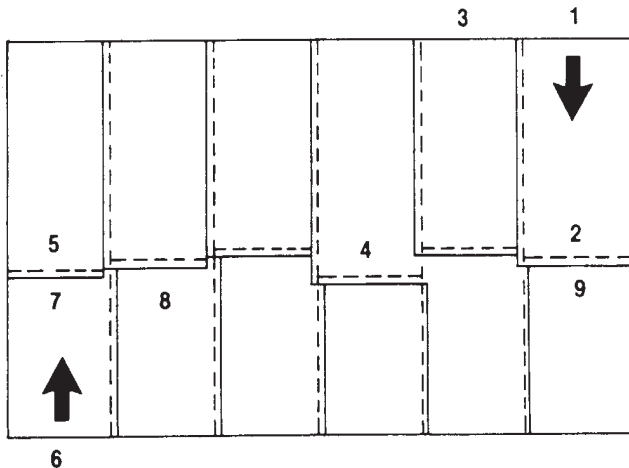


Figure 8B

How to Clean an Area of Carpet See Figure 8A

⚠ WARNING: Do not use water that is hotter than 120°F (48°C).

To clean an area of carpet, follow this procedure:

1. Start the pump for the solution and the motor for the vacuum on the extractor.
2. Begin at the right-hand corner of the carpet.
3. Hold the floor tool at the angle that gives the best vacuum seal between the tool and the carpet.
4. Apply pressure to the lever for solution release. Pull the tool toward you at a slow, steady speed. To remove as much solution as possible, release the lever before you stop moving backward. Push tool away over the same area while moving tool to next position. (Repeat process)
5. To clean the edge of a room, move the tool along the baseboard until the edge of all the carpet is cleaned.
6. To clean a small area of carpet, clean the carpet in sections three feet square. As you make more passes, repeat one inch of the area already cleaned.
7. To remove more liquid from the carpet, make passes over the area already cleaned, but do not apply pressure to the lever for the solution.


How To Clean A Larger Area Of Carpet See Fig. 8B

To clean a larger area of carpet, follow this procedure:

1. Begin at the right-hand corner of the carpet.
2. Make a pass halfway along the edge of the carpet. Pull the tool backward at a steady speed.
3. Move to the edge of the carpet. Make another pass next to your first pass.
4. As you make more passes, repeat one inch of the area already cleaned. If you use a power brush tool, repeat one inch of the area already cleaned by the brush. Make each pass four inches different in length to prevent making a line in the center of the carpet.
5. Make more passes until half of the carpet is cleaned. To remove more liquid from the carpet, make passes over the area already cleaned, but do not apply pressure to the lever for the solution.
6. Move to the right-hand corner of the part of the carpet not yet cleaned.
7. Make a pass halfway along the edge of the carpet.
8. As you make passes, repeat one inch of the area already cleaned.
9. Make more passes until all of the room is cleaned.

⚠ CAUTION: Clarke will not be held liable for damage to the carpet, or poor results because of the operator's lack of ability.

MAINTENANCE

 **WARNING:** Maintenance and repairs must be done by authorized personnel only. Keep all fasteners tight. Use only genuine Clarke parts.

 **WARNING:** Do not operate this machine unless it is completely assembled.

NOTE: For maintenance of the floor tools read the manual given with the tools.

After Each Use of the Machine

1. Remove unused cleaning solution from the solution tank, by placing the end of the vacuum hose in the solution tank. Start the vacuum motor. Stop the motor when the tank is empty.
2. To prevent damage to the valves and jets, flush one gallon of clean water through the solution system and the tools.
3. Disconnect the power cord from the outlet.
4. For optimum performance, flush the machine with clear water at the end of each working day. Once a month, minimum, run a flushing compound through the machine to cut any alkaline build-up that may have formed.
5. Lubricate wheels, casters, and hinges as needed. The pump and vacuum motor do not require any maintenance.
6. The body can be cleaned with a general all-purpose detergent and protected with a silicone type product. The quick-disconnects should be lubricated with silicone, also.
7. Prior to each job, inspect the holding tank filter and the recovery tank float filter for hair and dirt. The drain valve should also be inspected regularly and kept free of any debris or build-up.
8. Drain the recovery tank and dispose of properly.
9. Rinse the recovery tank with clean water.
10. Use a dry cloth to wipe the tools and both tanks, inside and out.
11. Apply a small amount of silicone lubricant to the quick-disconnect fittings. To prevent damage to the O-rings, do not use an oil lubricant.

MAINTENANCE (CONT)

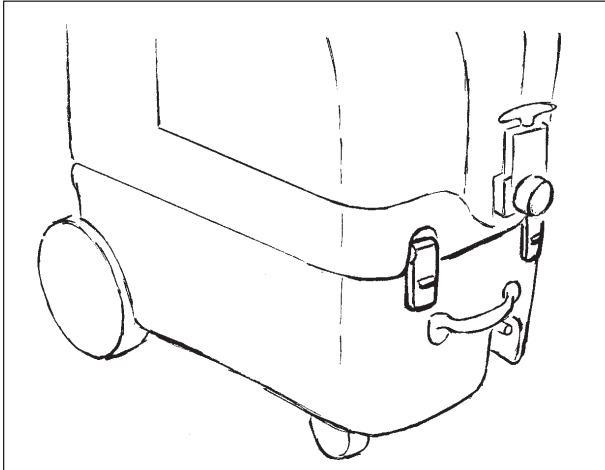


Figure 9a

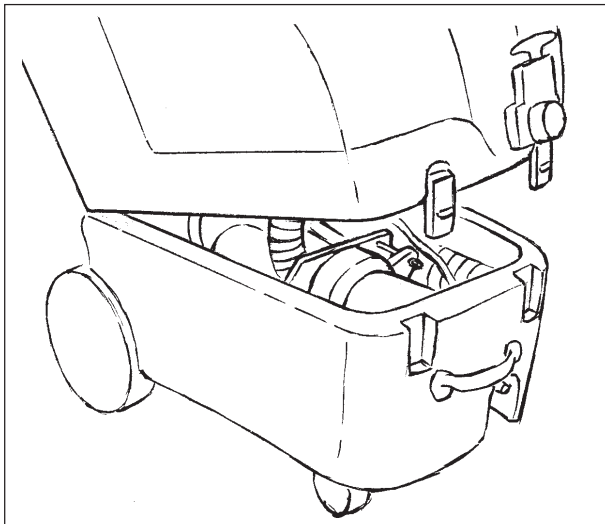


Figure 9b

How To Prevent Damage From Freezing Temperatures

To prevent damage from freezing temperatures follow this procedure:

1. Use the vacuum hose to remove all the solution from the clean solution tank.
2. Connect the solution hose to the extractor and a floor tool.
3. Put approximately 1 quart of antifreeze solution in the solution tank.
4. Put the switch for the pump in the "ON" position.
5. Put the end of the floor tool in the recovery pail.
6. Press the lever on the floor tool to activate the pump.
7. Make sure the solution runs through the system.
8. Release the lever on the floor tool to stop the pump.
9. Flush the antifreeze solution from the system before using the extractor.

⚠ WARNING: Electrical repairs must be done by authorized personnel only.

⚠ WARNING: After electrical repairs are done to the machine, the machine must be tested for electrical safety.

How To Get Access To The Pump and Vacuum Motor

To get access to the pump and the vacuum motor, follow this procedure (see figures 9a & 9b):

1. Empty both tanks.
2. Unlatch tanks from base.
3. Tilt tanks back.
4. Disconnect hoses from tanks.
5. Open up for service.

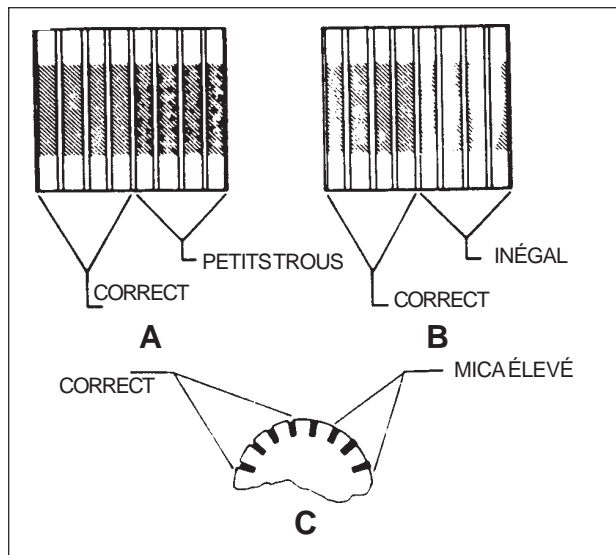
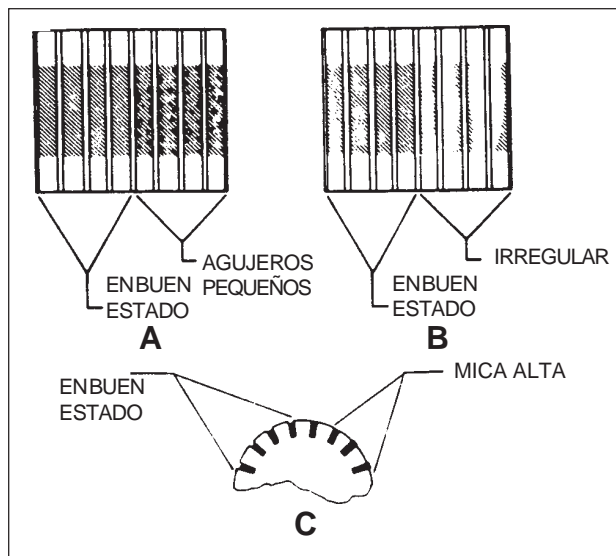
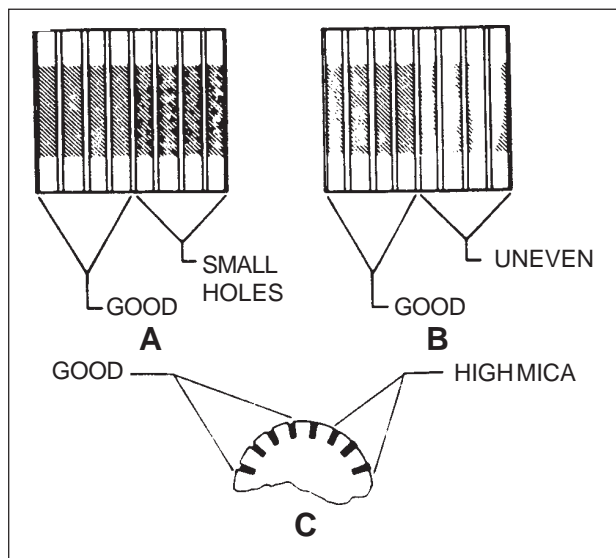


Figure 10

MAINTENANCE

Maintenance Of The Motor

This machine has a vacuum motor that uses carbon brushes. The carbon brushes in the motor must be checked every three months, or every 500 hours of operation, whichever comes first. If either of the brushes is shorter than 3/8 inch, replace both of the carbon brushes.

How To Check The Commutator And The Carbon Brushes

WARNING: Electrical inspections must be made by a person authorized to make electrical repairs.

To check the commutator and the carbon brushes follow this procedure:

1. Disconnect the power cord from the electrical outlet.
2. Empty both tanks.
3. Unlatch tanks from lower housing.
4. Lift the upper housing from the lower housing.
5. Disconnect the ground wire.
6. Remove the plastic motor cover.
7. Inspect the commutator. See figure 10. Take the machine to a Clarke authorized repair location if you see any of the following conditions:
 - a. Small holes in the surface of the commutator. See "A" in figure 11.
 - b. Uneven color. Look for an even dark brown color. Clean areas or very dark areas indicate a problem. See "B" in figure 11.
 - c. High mica. The mica insulation must be lower than the commutator bars. See "C" in figure 11.
8. To check the carbon brush assemblies, remove the two screws from the holding bracket.
9. Remove the brackets.
10. Remove the carbon brush assemblies.
11. Check the carbon brush assembly. Replace both carbon brush assemblies if either carbon brush is shorter than 3/8 inch. If either brush is shorter than 1/2 inch, order replacement brushes. Be ready to replace both carbon brushes earlier than the normal inspection time.
12. Put the motor brushes in position.
13. Using the two screws, install the bracket that holds the carbon brushes.
14. Install the plastic motor cover.
15. Connect the ground wire.
16. Install the motor holding bracket.
17. Install the lower housing to the upper housing.

HOW TO CORRECT PROBLEMS IN THE MACHINE

| Problem | Cause | Action |
|-------------------------------------|--|---|
| The machine will not run. | 1. The machine has no power. | 1. Make sure the machine is connected to the correct frequency and voltage, and all connections are tight. Make sure the plug is in the electrical outlet. |
| | 2. The power cord is damaged. | 2. Contact an authorized service person to replace the cord. |
| There is no suction. | 1. The vac motor does not run. | 1. Put the switch for the vacuum in the "I" position. |
| | 2. The vac motor switch is defective. | 2. Contact an authorized service person. |
| | 3. There is a loose motor connection. | 3. Contact an authorized service person. |
| | 4. There is an obstruction in the vacuum hose. | 4. Remove the obstruction. |
| | 5. The recovery tank is full. | 5. Remove the liquid from the tank. |
| | 6. The dome gasket is worn or damaged. | 6. Contact an authorized service person to replace gasket. |
| | 7. The internal vac hose is damaged or stopped. | 7. Contact an authorized service person. |
| | 8. The dome is damaged | 8. Replace the dome. |
| | 9. The motor brushes are worn. | 9. Replace the motor brushes. |
| | 10. Drain gate is open. | 10. Close drain gate. |
| | 11. Seals are damaged. | 11. Contact an authorized service person. |
| There is no pressure. | 1. The switch is in the "OFF" position. | 1. Put the switch in the "I" position. |
| | 2. The pressure switch is damaged. | 2. Contact an authorized service person. |
| | 3. The pump motor will not run. | 3. Contact an authorized service person. |
| | 4. The pump motor brushes are worn. | 4. Contact an authorized service person. |
| | 5. The quick disconnect fitting is dirty or stopped. | 5. Contact an authorized service person. |
| | 6. The solution hose is bent. | 6. Straighten the hose. Replace if damaged. |
| | 7. The pump is worn. | 7. Contact an authorized service person. |
| | 8. The pump switch is defective. | 8. Contact an authorized service person. |
| | 9. The pump connections are loose. | 9. Contact an authorized service person. |
| | 10. The pump intake and outlet valves are worn. | 10. Contact an authorized service person. |
| | 11. The thermal protector is open. | 11. Contact an authorized service person. |
| | 12. The solution tank is empty. | 12. Fill the solution tank. |
| | 13. The intake screen is dirty. | 13. Clean the screen. |
| | 14. The rectifier in the pump motor is bad. | 14. Contact an authorized service person. |
| The solution tank leaks. | 1. The tank is damaged. | 1. Contact an authorized service person. |
| The recovery tank overflows. | 1. The float is dirty or damaged. | 1. Clean the float. Replace if damaged. |
| | 2. There is too much foam. | 2. Put defoamer in the solution. Order P/N 398420. |
| | 3. The float gasket is dirty or damaged. | 3. Clean the gasket. Replace if damaged. |

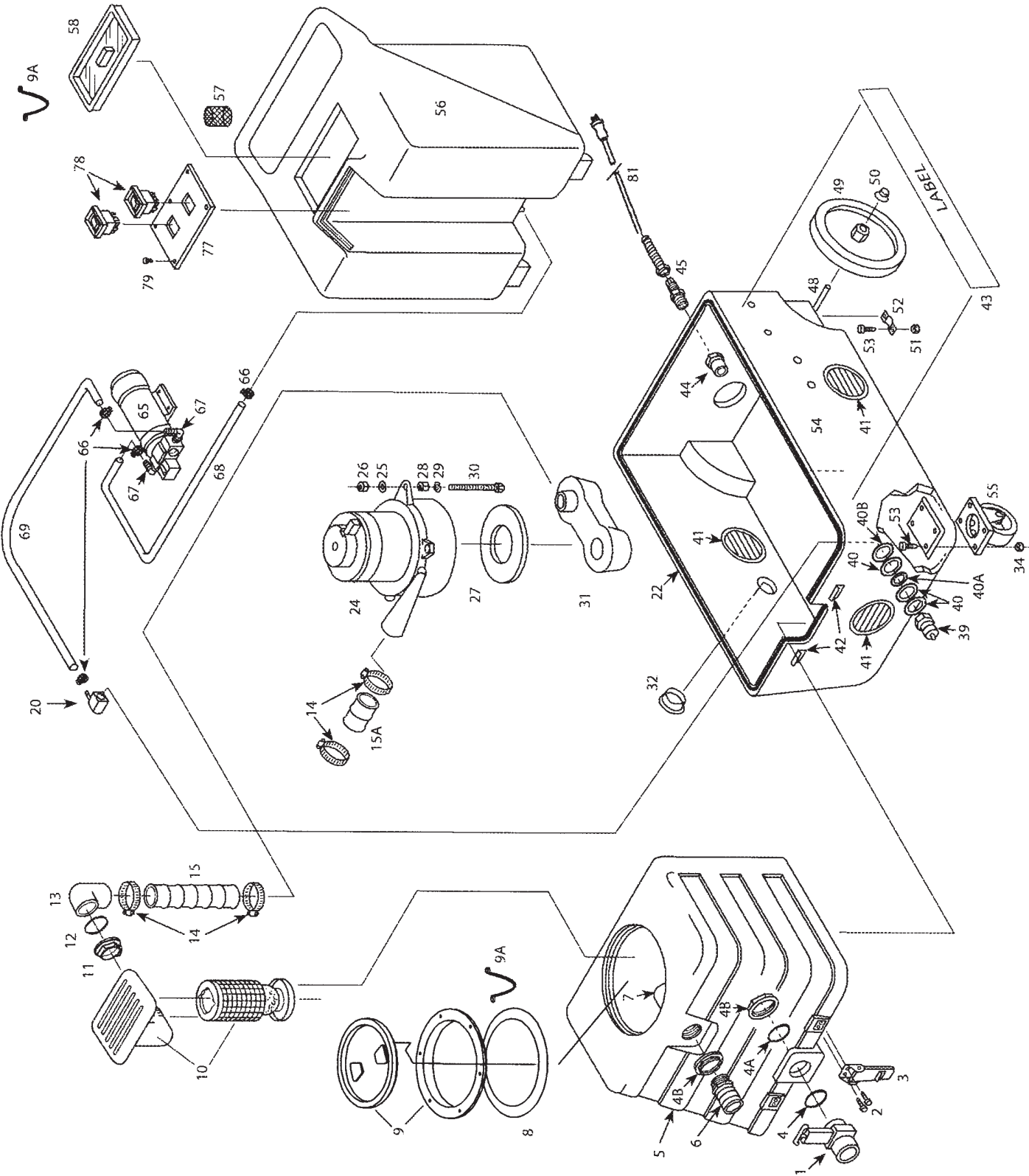
Clarke[®]

BEXT[®]-100, 100H, 150H, 300HV Extractor

**Section II
Parts and Service Manual**

(70416A)

Clarke® BEXT®-100, 120V
 Assembly Drawing 7/06



Clarke® BEXT®-100, 120V
Assembly Drawing Parts List 7/06

| Ref # | Part No. | Description | Qty | Ref # | Part No. | Description | Qty |
|-------|----------|----------------------------|-----|-------|----------|------------------------------|-----|
| 1 | 53876A | Drain Gate | 1 | 34 | 80335A | Lock Nut, ¼-20 | 8 |
| 2 | 80331A | Screw, 8-32 x 5/8" | 4 | 39 | 53885A | Quick Disconnect, Male ¼ PT | 1 |
| 3 | 52636A | Latch | 2 | 40 | 53895A | Washer, Fiber | 3 |
| 4 | 53877A | O-Ring | 1 | 40A | 54066A | Bushing, Fiber | 1 |
| 4A | 53878A | O-Ring | 1 | 40B | 80341A | Washer, Flat Brass | 1 |
| 4B | 80332A | Nut, Aluminum, ½" | 1 | 41 | 52763A | Louver 3", includes screws | 3 |
| 5 | 53861A | Vacuum Tank Complete | 1 | 42 | 52675A | Strike, Latch | 2 |
| 6 | 53879A | Hose Bar, 1½" | 1 | 43 | | Label | 2 |
| 7 | 53880A | Elbow, PVC | 1 | 44 | 52675A | Reducer, Bushing PVC | 1 |
| 8 | 53881A | Gasket, Lid Vacuum | 1 | 45 | 53798A | Cord, Retainer Flexible | 1 |
| 9 | 53882A | Lid, Clear 6" w/ring | 1 | 48 | 53898A | Axle, Rod 17" | 1 |
| 9A | 53883A | Chain Assembly, for lids | 2 | 49 | 53867A | Wheel, 8" | 2 |
| 10 | 53884A | Manifold, with Ball/Cage | 1 | 50 | 53899A | Axle, Cap | 2 |
| 11 | 80332A | Nut, Aluminum 1½" | 1 | 51 | 80335A | Lock Nut, ¼-20 | 4 |
| 12 | 53877A | O-Ring | 1 | 52 | 54069A | Bracket, Axle | 2 |
| 13 | 53880A | Elbow, PVC | 1 | 53 | 80343A | Bolt, ¼-20 x ¾" | 12 |
| 14 | 53887A | Hose Clamp | 4 | 54 | 53863A | Base, Black | 1 |
| 15 | 53888A | Hose, 2" x 21" | 1 | 55 | 53866A | Castor, 3" | 2 |
| 15A | 53889A | Hose, 2" x 2" | 1 | 56 | 53862A | Holding Tank, Blue | 1 |
| 20 | 53893A | Elbow | 1 | 57 | 53872A | Filter, 40 Mesh SS | 1 |
| 22 | 53894A | Gasket | 1 | 58 | 54070A | Lid, Tinted | 1 |
| 24 | 40954A | Vacuum Motor, 3-Stage | 1 | 65 | 53869A | Pump, 100PSI | 1 |
| 25 | 80334A | Washer, Flat | 3 | 66 | 54071A | Hose Clamp | 4 |
| 26 | 80335A | Lock Nut, ¼-20 | 3 | 67 | 54072A | Hose Barb, Elbow | 2 |
| 27 | 53896A | Gasket, Vacuum | 1 | 68 | 54073A | Hose, Pump Inlet ¾ ID x 13" | 1 |
| 28 | 80336A | Nut, Finish | 3 | 69 | 54074A | Hose, Pump Outlet ID ¾ x 22" | 1 |
| 29 | 80334A | Washer, Flat | 3 | 77 | 53868A | Switch Plate | 1 |
| 30 | 80338A | Bolt, ¼-20 x 5" | 3 | 78 | 52842A | Switch, Rocker w/cover | 2 |
| 31 | 53897A | Manifold, Vac Motor, Black | 1 | 79 | 80345A | Screw, #4 x 3/8" | 5 |
| 32 | 52672A | Exhaust Flange | 1 | 81 | 40637A | Cord, Power 12-3, 25" | 1 |

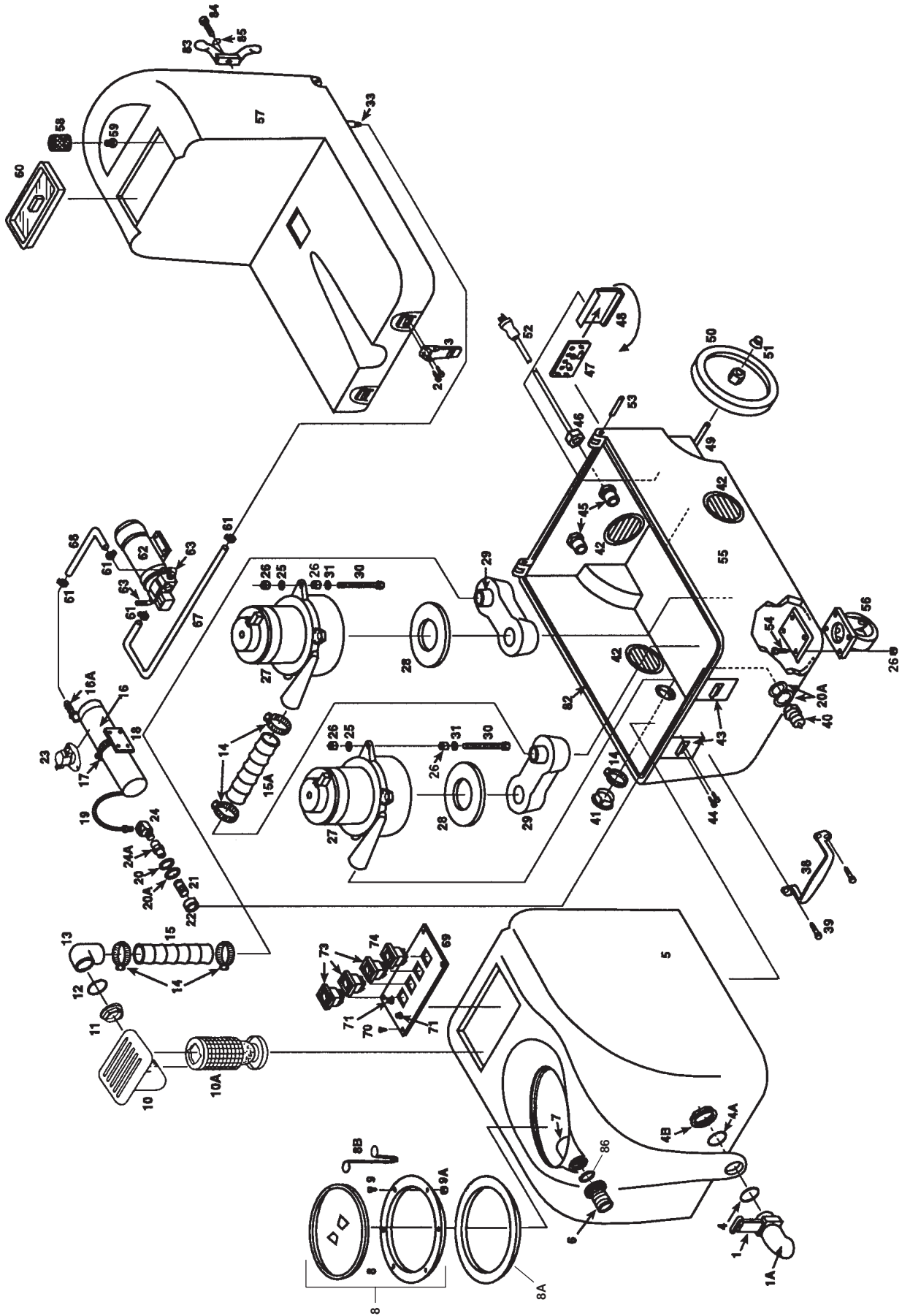
Clarke® BEXT®-100H, 120V
 Assembly Drawing 7/06



Clarke® BEXT®-100H, 120V
Assembly Drawing Parts List 7/06

| Ref # | Part No. | Description | Qty | Ref # | Part No. | Description | Qty |
|-------|----------|----------------------------|-----|-------|----------|---|-----|
| 1 | 53876A | Drain Gate | 1 | 34 | 80335A | Lock Nut, ¼-20 | 8 |
| 2 | 80331A | Screw, 8-32 x 5/8" | 4 | 39 | 80340A | Quick Disconnect, Male ¼ PT | 1 |
| 3 | 52636A | Latch | 2 | 40 | 53895A | Washer, Fiber | 3 |
| 4 | 53877A | O-Ring | 1 | 40A | 54066A | Bushing, Fiber | 1 |
| 4A | 53878A | O-Ring | 1 | 40B | 80341A | Washer, Flat Brass | 1 |
| 4B | 80332A | Nut, Aluminum, ½" | 1 | 41 | 52763A | Louver 3", includes screws | 3 |
| 5 | 53861A | Vacuum Tank Complete | 1 | 42 | 52675A | Strike, Latch | 2 |
| 6 | 53879A | Hose Bar, 1½" | 1 | 43 | 71194A | Label | 2 |
| 7 | 53880A | Elbow, PVC | 1 | 44 | 52675A | Reducer, Bushing PVC | 1 |
| 8 | 53881A | Gasket, Lid Vacuum | 1 | 45 | 53798A | Cord, Retainer Flexible | 1 |
| 9 | 53882A | Lid, Clear 6" w/ring | 1 | 46 | 54067A | Dual Cord Circuit Board | 1 |
| 9A | 53883A | Chain Assembly, for lids | 2 | 47 | 54068A | Snap Track, Circuit Board Mounting | 1 |
| 10 | 53884A | Manifold, with Ball/Cage | 1 | 48 | 53898A | Axle, Rod 17" | 1 |
| 11 | 80332A | Nut, Aluminum 1½" | 1 | 49 | 53867A | Wheel, 8" | 2 |
| 12 | 53877A | O-Ring | 1 | 50 | 53899A | Axle, Cap | 2 |
| 13 | 53880A | Elbow, PVC | 1 | 51 | 80335A | Lock Nut, ¼-20 | 4 |
| 14 | 53887A | Hose Clamp | 4 | 52 | 54069A | Bracket, Axle | 2 |
| 15 | 53888A | Hose, 2" x 21" | 1 | 53 | 80343A | Bolt, ¼-20 x ¾" | 12 |
| 15A | 53889A | Hose, 2" x 2" | 1 | 54 | 53863A | Base, Black | 1 |
| 16 | 53890A | Heat Exchanger, complete | 1 | 55 | 53866A | Castor, 3" | 2 |
| 16A | | See Misc. Parts List | | 56 | 53862A | Holding Tank, Blue | 1 |
| 17 | 53891A | Hose Clamp | 1 | 57 | 53872A | Filter, 40 Mesh SS | 1 |
| 18 | 53892A | Bracket, Heater Mounting | 1 | 58 | 54070A | Lid, Tinted | 1 |
| 19 | 53870A | Hose, Heater to outlet | 1 | 65 | 53869A | Pump, 100PSI | 1 |
| 20 | 53893A | Elbow | 1 | 66 | 54071A | Hose Clamp | 4 |
| 22 | 53894A | Gasket | 1 | 67 | 54072A | Hose Barb, Elbow | 2 |
| 24 | 40954A | Vacuum Motor, 3-Stage | 1 | 68 | 54073A | Hose, Pump Inlet 3/8 ID x 13" | 1 |
| 25 | 80334A | Washer, Flat | 3 | 69 | 54074A | Hose, Pump Outlet ID 3/8 x 48" | 1 |
| 26 | 80335A | Lock Nut, ¼-20 | 3 | 70 | 80344A | Lock Nut | |
| 27 | 53896A | Gasket, Vacuum | 1 | 77 | 54075A | Switch Plate | 1 |
| 28 | 80336A | Nut, Finish | 3 | 78 | 53842A | Switch, Rocker w/cover | 3 |
| 29 | 80334A | Washer, Flat | 3 | 79 | 80345A | Screw, #4 x 3/8" | |
| 30 | 80338A | Bolt, ¼-20 x 5" | 3 | 80 | 54076A | Light, Green | 1 |
| 31 | 53897A | Manifold, Vac Motor, Black | 1 | 81 | 40637A | Cord, Power 12-3, 25" | 2 |
| 32 | 52672A | Exhaust Flange | 1 | NI | 54077A | Heat Repair Kit (incl. cutout & thermostat) | |

Clarke® BEXT®-150H, 120V
Assembly Drawing 11/05



Clarke® BEXT®-150H, 120V
Parts List 3/06

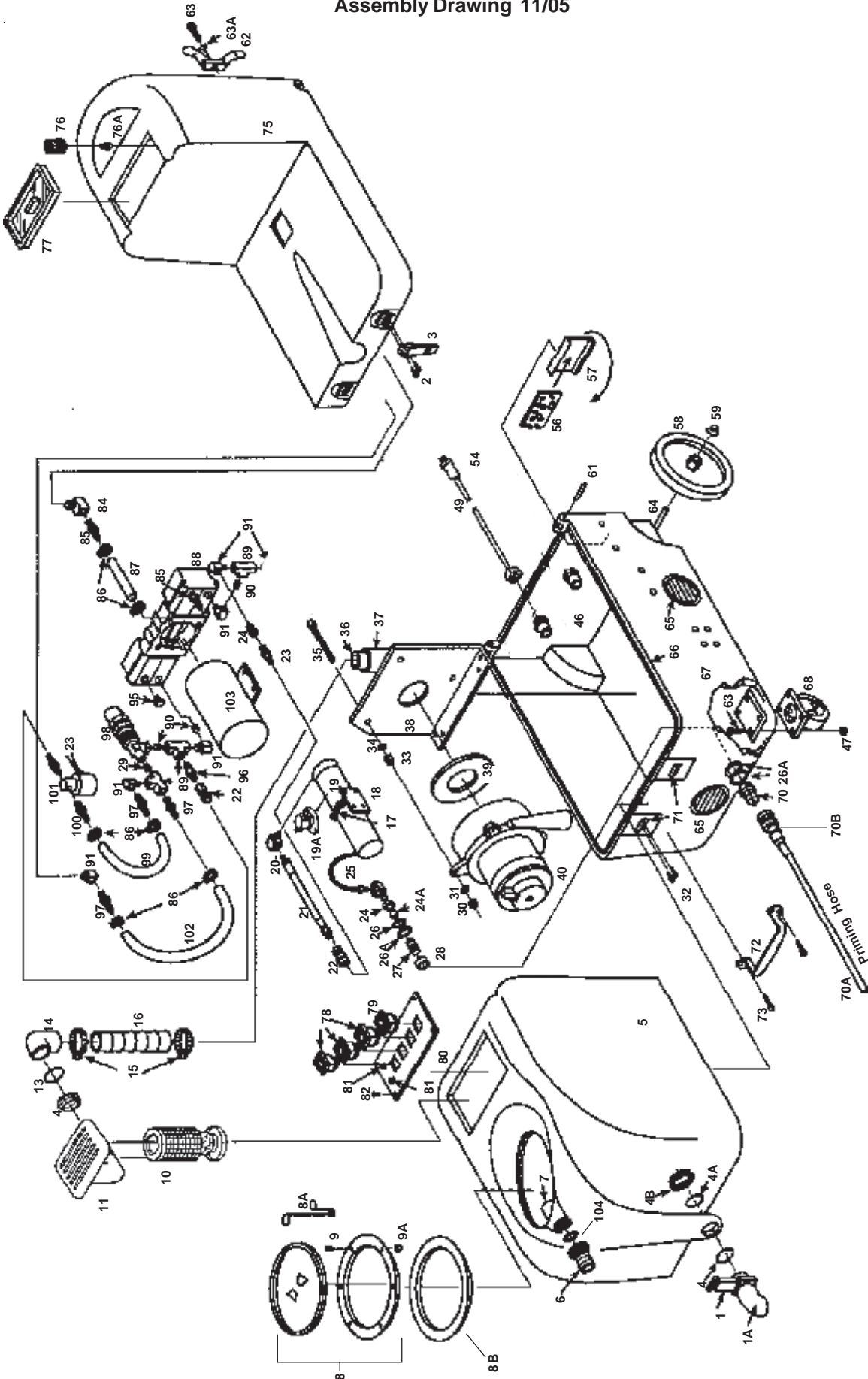
| Ref # | Part No. | Description | Qty | Ref # | Part No. | Description | Qty |
|-------|----------|--|-----|-------|----------|-----------------------------|-----|
| 1 | 59721A | Valve-Drain | 1 | 39 | 962098 | Screw, ¼ -20 x 3/4 | 1 |
| 1A | 53606A | Elbow-45 Degree, Drain | 1 | 40 | 52840A | Quick Disconnect | 1 |
| 2 | 962929 | Screw, 10-32 x ¾ | 1 | 41 | 52672A | Flange, Exhaust | 1 |
| 3 | 52636A | Latch, Tank | 2 | 42 | 52673A | Louvre, (includes hardware) | 3 |
| 4 | 837304 | O-Ring (Small) | 1 | 43 | 52674A | Strike, Latch | 2 |
| 4A | | | | 44 | | | |
| 4B | 920797 | Nut Drain Valve Lock | 2 | 45 | 52675A | Reducer, PVC | 2 |
| 5 | 30322A | Tank, Recovery | 1 | 46 | 52676A | Retainer, Cord | 2 |
| *6 | 690212 | Adaptor Asm.-Vac Hose | 1 | 47 | 40661A | Sensor, Dual Cord | 1 |
| *7 | 692701 | Elbow - 90 Degree | 1 | 48 | 52664A | Snap Track, 4" | 1 |
| 8 | 55674A | Lid 6" Clear | 1 | 49 | 61388A | Axle, Wheel | 1 |
| 8A | 34288A | Gasket** | 1 | 50 | 52471A | Wheel, 10" | 1 |
| 8B | 692409 | Chain-Cover | 1 | 51 | 920346 | Axle, Cap | 2 |
| 9 | 85613A | Screw, 8-32 x 7/8 Pan Hd | 1 | 52 | 40637A | Cord, Power | 1 |
| 9A | 81109A | Nut, Hex Elastic Lock | 1 | 53 | 61339A | Pin, Hinge | 2 |
| 10 | 52806A | Vac Manifold Asm. (incl. 10, 10A, 11, 12, 13) | 1 | 54 | 170915 | Screw, ¼-20 x ¾ | 8 |
| 11 | 920797 | Nut Drain Valve | 2 | 55 | 30324A | Housing, Lower | 1 |
| 12 | | | | 56 | 52470A | Castor, 4" Grey | 2 |
| 13 | 30323A | Elbow, Vac Manifold | 1 | 57 | 30195A | Holding Tank | 1 |
| 14 | 872010 | Hose clamp | 1 | 58 | 52841A | Filter, Inlet | 1 |
| 15 | 52666A | Hose Vacuum Tank | 1 | 59 | 52677A | Adaptor, Inlet Screen | 1 |
| 15A | 52667A | Hose, Vacuum to Manifold | 1 | 60 | 53558A | Solution, Tank Lid | 1 |
| 16 | 52566A | Heater, Complete | 1 | 61 | 50248A | Hose Clamp | 1 |
| 16A | 732870 | Hosebarb | 1 | 62 | 51206A | Pump, Solution | 1 |
| 17 | | | | 63 | 170030 | Hosebarb, ¾ PT x ¼ Barb | 1 |
| 18 | | | | 64 | | | |
| 19 | 30323A | Hose, Braided Heater | 1 | 65 | | | |
| 20 | 52993A | Washer, Brass | 1 | 66 | | | |
| 20A | 52992A | Washer, Fibre | 1 | 67 | 30326A | Hose, Inlet | 1 |
| 21 | | Nipple, ¼ NPT SS | 1 | 68 | 962454 | Hose, Outlet | 1 |
| 22 | 52995A | Busing, Fiber | 1 | 69 | 52678A | Switch Plate | 1 |
| 23 | 52834A | Thermostat, Heater | 1 | 70 | | | |
| 24 | 53639A | Elbow, Brass | 1 | 71 | 52668A | Light, Green | 2 |
| 24A | | Coupling | 1 | 72 | | | |
| 25 | 87026A | Washer ¼ | 6 | 73 | 52842A | Switch, Vacuum / Pump | 3 |
| 26 | 81102A | Nut, ¼ -20 | 1 | 74 | 52843A | Switch, Pump | 1 |
| 27 | 44906A | Motor, Vac | 1 | 75 | | | |
| 27A | 40833A | Brush, Carbon | 2 | 76 | | | |
| 28 | 30197A | Gasket, Vac Motor | 2 | 77 | | | |
| 29 | 52670A | Vacuum, Manifold | 2 | 78 | | | |
| 30 | 85742A | Screw, ¼-20 | 6 | 79 | | | |
| 31 | 87026A | Washer | 6 | 80 | | | |
| 32 | | | | 81 | | | |
| 33 | 170030 | Hosebarb | 1 | 82 | 30635A | Gasket, Base | 1 |
| 34 | | | | 83 | 52679A | Cord Wrap | 2 |
| 35 | | | | 84 | 962454 | Screw, ¼-20 x 1 | 2 |
| 36 | | | | 85 | | | |
| 37 | | | | *86 | 693406 | Gasket | 1 |
| 38 | 52671A | Handle, Lifting | 1 | | | | |

* Items 6, 7 & 86 must be ordered as a set when replacing any original #6 Adapter and
 3 - 85522A Screws
 1 - 962109 Screw
 1 - 920296 Nut

** Item 8A must be used with any lid replacement.

| Part # | Miscellaneous Assemblies/Parts |
|--------|---|
| 52847A | Heat Repair Kit w/ Thermostat and Cutout Asm. |

Clarke® BEXT®-300HV, 120V
 Assembly Drawing 11/05



Clarke® BEXT®-300HV, 120V

Parts List 3/06

| Ref # | Part No. | Description | Qty | Ref # | Part No. | Description | Qty |
|-------|----------|---|-----|-------|----------|------------------------------------|-----|
| 1 | 59721A | Drain Gate (see misc) | 1 | 54 | | | |
| 1A | 53606A | Spout, Drain Gate | 1 | 55 | | | |
| 2 | 962929 | Screw, 10-32 x 3/8, SS | 4 | 56 | 40661A | Dual Cord Sensor, Circuit Board | 1 |
| 3 | 52636A | Latch | 2 | 57 | 52664A | Mount, Dual Cord Sensor | 1 |
| 4 | 837304 | O-Ring (small) | 3 | 58 | 52471A | Wheel, 10" | 2 |
| 4A | | | | 59 | 920346 | Axle Cap | 2 |
| 4B | 920797 | Drain Valve | 2 | 61 | 61339A | Hinge Rod, 1/4 x 3 1/2", SS | 2 |
| 5 | 30322A | Tank, Recovery | 1 | 62 | 52679A | Cord Wrap | 2 |
| *6 | 690212 | Adaptor | | 63 | 170915 | Screw, 1/40-20 x 1", SS | 2 |
| *7 | 692701 | PVC Elbow, 1 1/2" | | 63A | 87026A | Washer, 1/4, SS | 2 |
| 8 | 55674A | Lid & Ring, 6" | 1 | 64 | 61338A | Axle, 18" | 1 |
| 8A | 692409 | Chain Assembly, 8" | 1 | 65 | 52673A | Louver, 3" | 1 |
| 8B | 34288A | Gasket** | 1 | 66 | 30635A | Gasket, Base | |
| 9 | 85613A | Screw, 8-32 x 7/8" | | 67 | 40750A | Housing, Lower | |
| 9A | 81109A | Nut, 8/32, SS Nylock | | 68 | 52470A | Castor, 4" x 1" | 1 |
| 10 | | | | 69 | | Bolt, 1/4-20 x 3/4" | 2 |
| 11 | 52806A | Vacuum Mainfold, Incl. Ball & Cage (includes 10, 10A, 11, 12 and 13) | 1 | 70 | 52840A | Quick Disconnect, Male 1/4" PT | |
| 12 | | | | 70A | 61314A | Priming Hose | 1 |
| 13 | | | | 70B | 52565A | Quick Disconnect, Female 1/4 PT | 1 |
| 14 | | | | 71 | 52674A | Latch Strike | 2 |
| 15 | 872010 | Hose Clamp | 2 | 72 | 52671A | Handle, Lifting | 1 |
| 16 | 52665A | Hose, Rubber | | 73 | 962098 | Screw, Flathead | 4 |
| 17 | 52365A | Hose Clamp | | 75 | 30338A | Tank, Solution | 1 |
| 18 | | Heat Exchanger Mount | 1 | 76 | 52841A | Filter, Pump Inlet | 1 |
| 19 | 52566A | Heat Exchanger, Complete | 1 | 76A | 52677A | Adapter, Inlet Screen | |
| 19A | 52834A | Thermostat, Heat Switch (see misc) | 1 | 77 | 53558A | Lid, Solution Tank | 1 |
| 20 | | | | 78 | 52842A | Switch, Pump & Vacuum | 3 |
| 21 | 61350A | Hose, 26", High Pressure 1/4 I.D. | 1 | 79 | 52843A | Switch, Heat | 1 |
| 22 | 52988A | Quick Disconnect, Open 1/8", PT | 2 | 80 | 52678A | Panel, Control | 1 |
| 23 | 52989A | Quick Disconnect, Male, 1/8" PT | 2 | 81 | 52668A | Green Light | 2 |
| 24 | 851144 | Bushing Brass, 1/4 MPT x 1/8 FPT | 1 | 82 | | Screw, #4 x 3/8 SS | |
| 24A | 52991A | Coupling | | 84 | 53639A | Elbow 90°, 1/4 PT | |
| 25 | 30323A | Hose, Braided, SS | 1 | 85 | 52171A | Hose Barb, 1/4 PT x 1/2" Hose | |
| 26 | 52992A | Washer, Brass | | 86 | 50248A | Hose Clamp | 8 |
| 26A | 52993A | Washer, Fiber | | 87 | | Hose, Pump Inlet, 1/2" x 14" | |
| 27 | | | | 88 | | Pump, No Fittings (see misc.) | |
| 28 | 52995A | Bushing, Fiber | 1 | 89 | 170066 | "T" Brass, 1/4 PT | |
| 29 | | | | 90 | 170086 | Nipple, SS, 1/4 PT | |
| 30 | | Lock Nut, 5/16" | | 91 | 170040 | Elbow Brass, 1/4 MPT x 1/4 FPT | |
| 31 | | Washer, 5/16" | | 92 | | Quick Disconnect, Male 1/4 PT | |
| 32 | | Screw, 10-32 x 5/8", SS | | 93 | | | |
| 33 | | Nut, 5/16" | | 94 | | | |
| 34 | | Washer, 5/16" | | 95 | 696801 | Plug, Brass | |
| 35 | | Bolt, 5/16 x 4" | | 96 | 697501 | Reducing Nipple, 1/4 MPT x 1/8 MPT | |
| 36 | 52997A | PVC Sleeve, 3" | | 97 | 170030 | Hose Barb, Brass 1/4 PT x 3/8 Hose | |
| 37 | 52998A | PVC Elbow, 90°, 1 1/2", Slip | | 98 | 53173A | Bypass Valve (see misc.) | |
| 38 | 61351A | Mount Plate | 1 | 99 | 53174A | Hose, 3/8" x 8" | |
| 39 | 52835A | Gasket (Vacuum Motor) | 1 | 100 | 690209 | Hose Barb, Brass 1/8 PT x 3/8 Hose | |
| 40 | 52836A | Vacuum Motor (120V) | 1 | 101 | 52844A | Solenoid (120V), NC | 1 |
| 41 | | | | 102 | 53175A | Hose, Pump Bypass, 3/8" x 14" | |
| 42 | | | | 103 | 52837A | Motor, for Pump (AC, 120V) | 1 |
| 43 | | | | *104 | 693406 | Gasket, Swivel | 1 |
| 44 | | | | | | | |
| 46 | | PVC Reducer | | | | | |
| 47 | | Lock Nut | | | | | |
| 49 | 40637A | Power Cord, 12/3, 25 ft. | 2 | | | | |
| 50 | | | | | | | |
| 51 | 52676A | Cord Retainer, Water Tight | 2 | | | | |
| 52 | | | | | | | |
| 53 | | | | | | | |

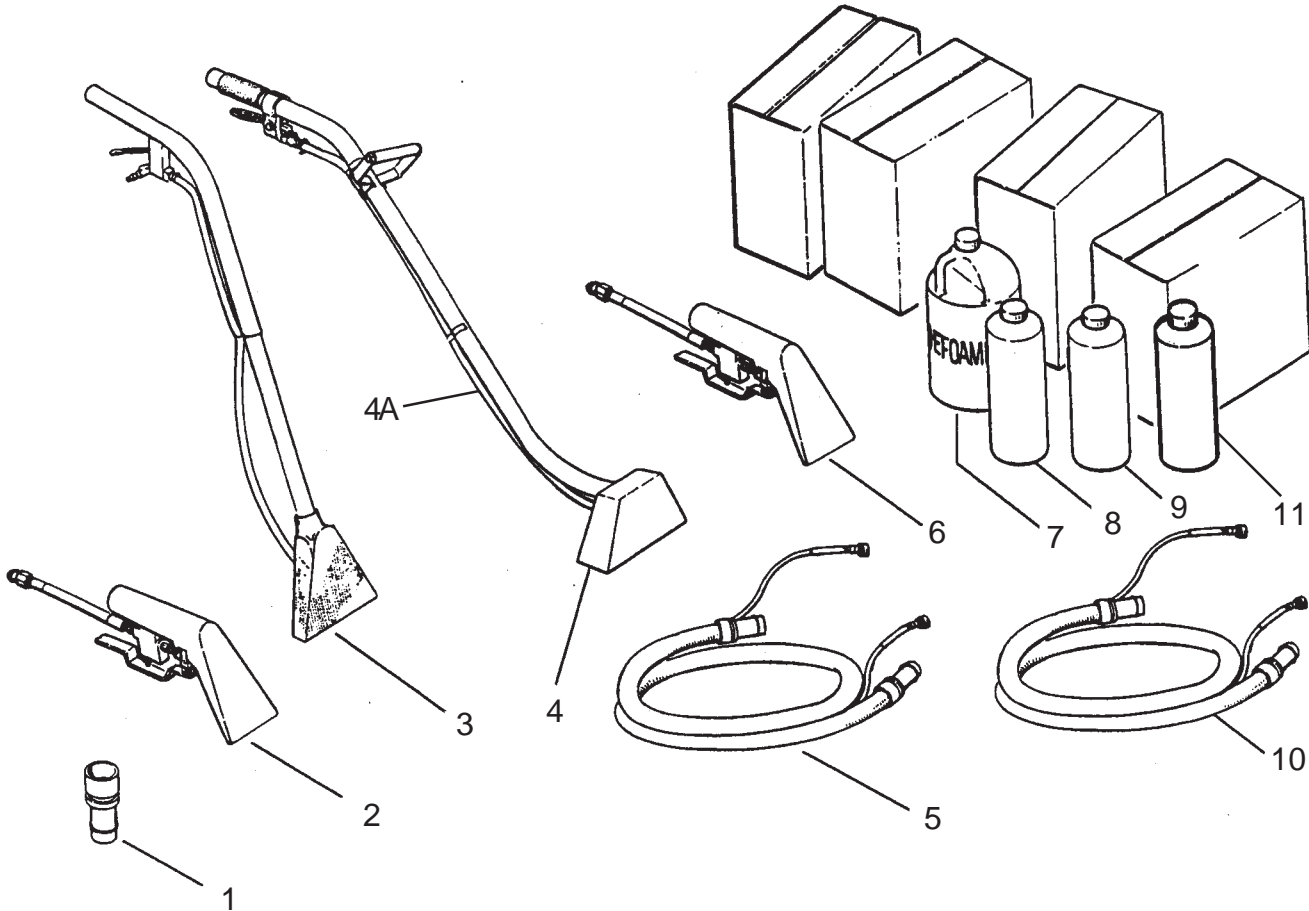
* Items 6, 7 & 104 must be ordered as a set when replacing any original #6 Adapter and: 3 - 85522A Screws, 1 - 962109 Screw, 1 - 920296 Nut.

** Item 8B must be used with any lid replacement.

| Part # | Miscellaneous Assemblies/ Parts |
|--------|---|
| 52848A | Bypass Rebuild Kit |
| 52846A | Valve/O-Ring Kit |
| 52849A | Plunger & Seals Kit |
| 53389A | Pump Complete (no motor or solenoid) |
| | Pump Complete with Solenoid |
| | Pump & Motor Complete with Solenoid |
| 52845A | Bearing/Cam Asm. (for pump) |
| | Drain Gate Complete w/ O-Rings, Nut & Spout |
| 52847A | Heat Repair Kit w/Thermostat & Cutout Asm. |
| | Label, Clarke |

Clarke®
BEXT®-100 Accessories
 Drawing & Parts List 3/06

⚠ WARNING: Do not use *Bext 100* accessories on heated units (Bext 100H, 150H & 300HV). Injury to operator or bystanders could occur. Damage to the machine could occur.

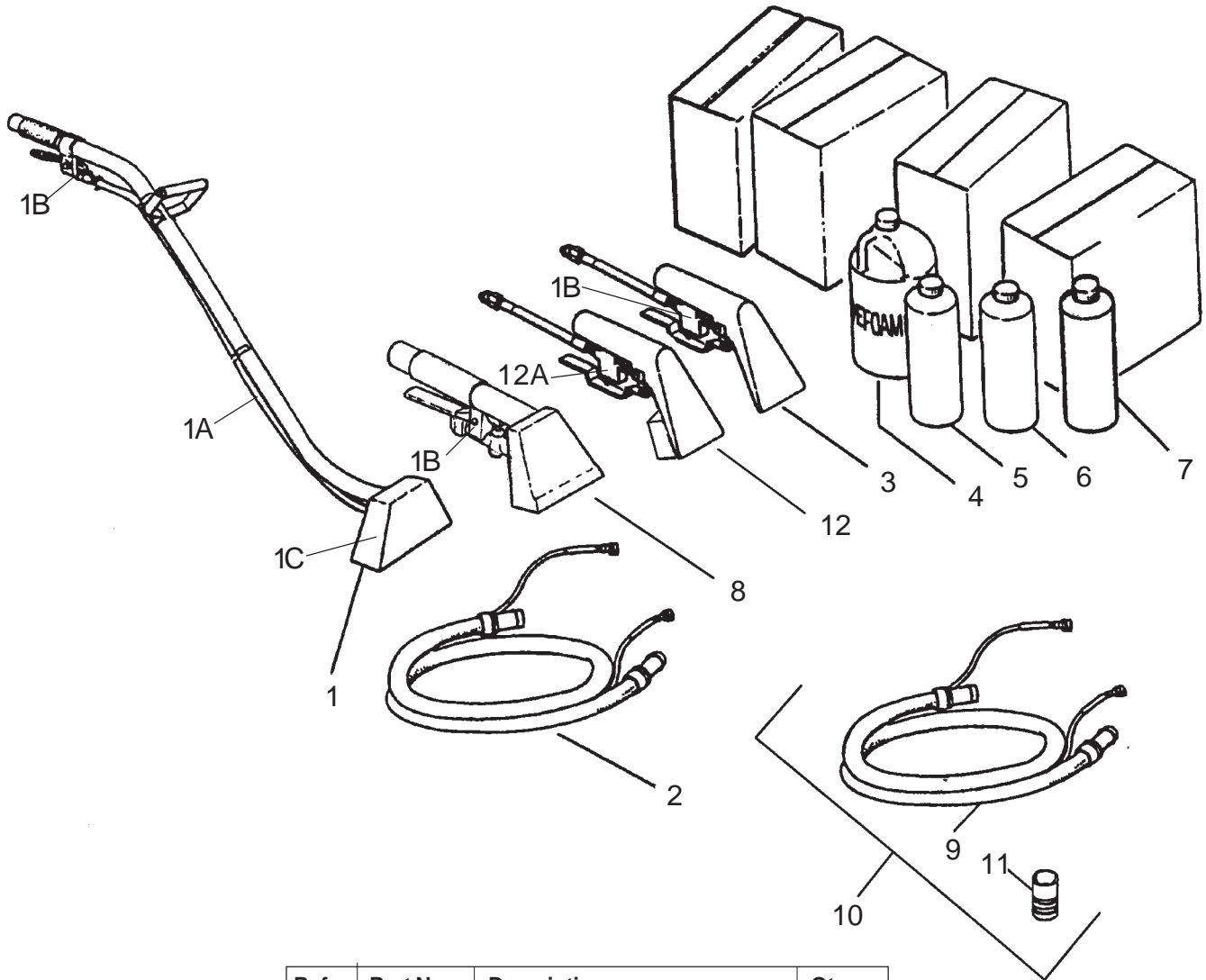


| Ref | Part No. | Description | Qty |
|-----|----------|--------------------------------|---------|
| 1 | 30108A | Adaptor, 2" to 1½" | 1 |
| 2 | 59231A | RM-4P Tool Assembly | 1 |
| 3 | 59230A | RM-8P Tool Assembly | 1 |
| 4 | 61393A | RM-12M Tool Assembly | 1 |
| 4A | 30496A | Hose Asm. , Squeegee | 1 |
| 5 | 59232A | Hide-A- Hose 10' | 1 |
| 6 | 59228A | RM-4M Tool Assembly | 1 |
| 7 | 398426 | Defoamer | *1 case |
| 8 | 398425 | Extractor, Concentrate | *1 case |
| 9 | 398427 | Traffic Lane/Spot Cleaner | *1 case |
| 10 | 55183A | Hide-A-Hose 20' | 1 |
| 11 | 52953A | General Purpose Spot Cleaner | 1 case |
| ASM | 55173A | 4" Hand Tool and 10' Hose Asm. | 1 |
| NI | 682408 | Coupler, 1½" Hose Connector | 1 |

* 4, 1 gallon bottles

NOTE: u indicates a change has been made since the last publication of this manual.

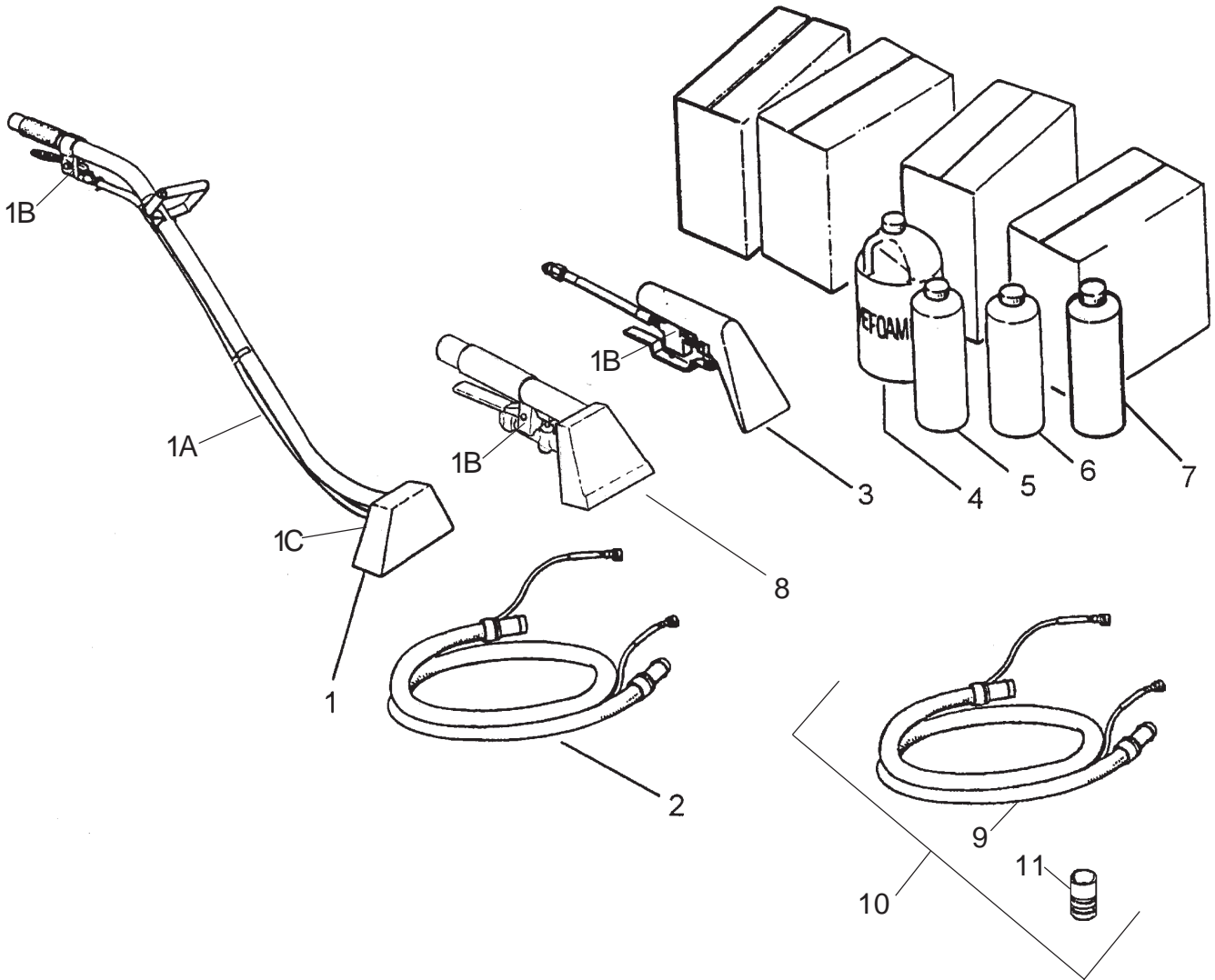
Clarke®
BEXT® 100H, 150H Detailer Accessories
Drawing & Parts List 6/04



| Ref | Part No. | Description | Qty |
|-----|----------|------------------------------|---------|
| 1 | 61394A | 12" Wand | 1 |
| 1A | 30496A | Hose Asm., Solution | 1 |
| 1B | 52544A | Valve Body | 1 |
| 1C | 52996A | Nozzle, Spray | 2 |
| 2 | 52469A | Hose 15' | 1 |
| 3 | 52833A | Tool, 3½ HP | 1 |
| 4 | 398426 | Defoamer | *1 case |
| 5 | 398425 | Extractor, Concentrate | *1 case |
| 6 | 398427 | Traffic Lane/Spot Cleaner | *1 case |
| 7 | 52953A | General Purpose Spot Cleaner | 1 case |
| 8 | 52832A | Tool, 4" Closed | 1 |
| 9 | 30229A | 15" Hose Extension | 1 |
| 10 | 10386A | Kit, 15" Hose Ext. w/Coupler | 1 |
| 11 | 682408 | 1.50 Dia. Hose Coupler | 1 |
| 12 | 52514A | Tool, 3 1/2 Closed Detail | 1 |
| 12A | 53557A | Valve, Body | 1 |

* 4, 1 gallon bottles

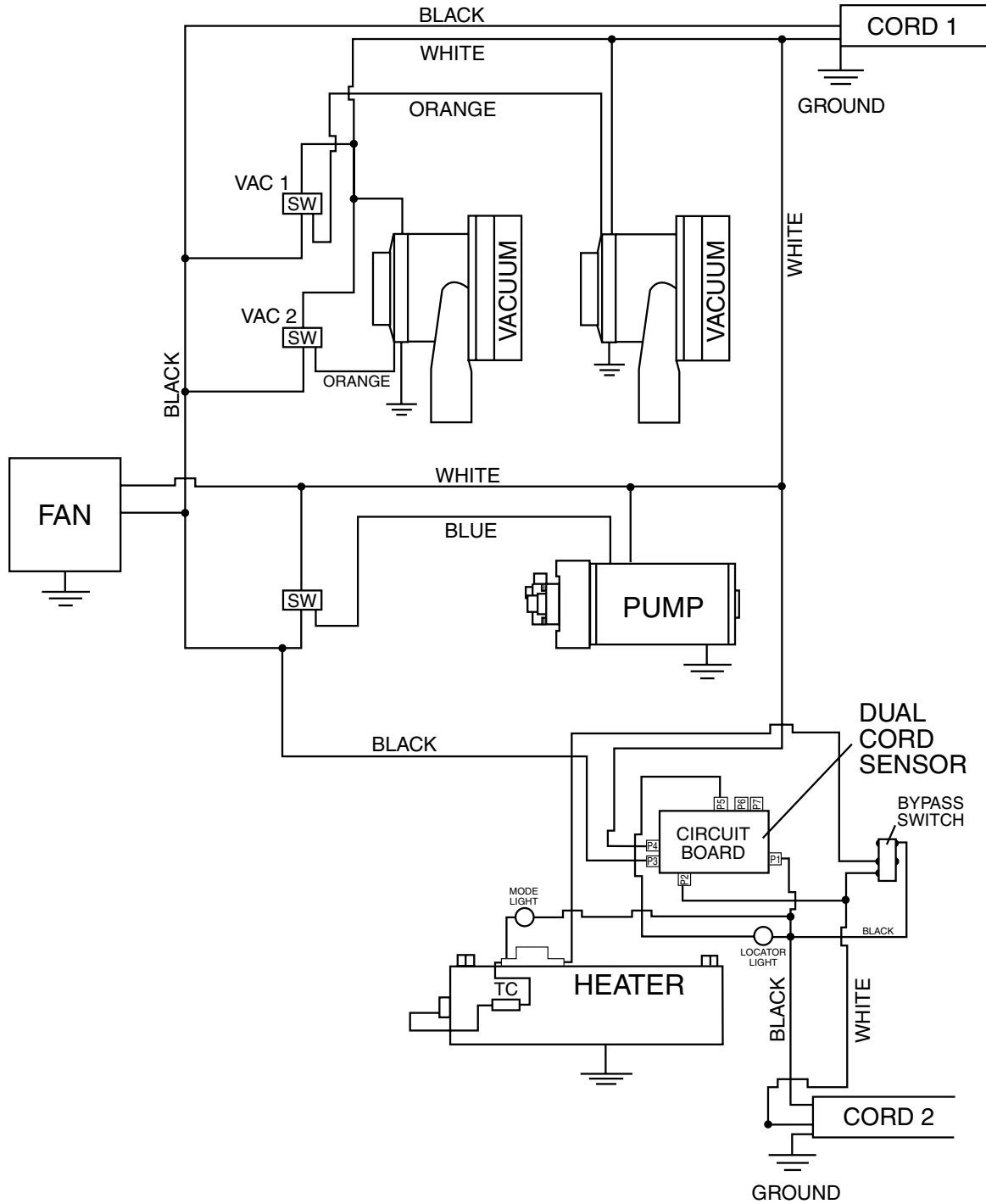
Clarke®
BEXT® 300HV Accessories
Drawing & Parts List 1/04



| Ref | Part No. | Description | Qty |
|-----|----------|------------------------------|---------|
| 1 | 61395A | 12" Wand | 1 |
| 1A | 30496A | Hose Asm., Solution | 1 |
| 1B | 52544A | Valve Body | 1 |
| 1C | 52996A | Nozzle, Spray | 2 |
| 2 | 52469A | Hose 15' | 1 |
| 3 | 52833A | Tool, 3½ HP | 1 |
| 4 | 398426 | Defoamer | *1 case |
| 5 | 398425 | Extractor, Concentrate | *1 case |
| 6 | 398427 | Traffic Lane/Spot Cleaner | *1 case |
| 7 | 52953A | General Purpose Spot Cleaner | 1 case |
| 8 | 52832A | Tool, 4" Closed | 1 |
| 9 | 30229A | 15" Hose Extension | 1 |
| 10 | 10386A | Kit, 15" Hose Ext. w/Coupler | 1 |
| 11 | 682408 | 1.50 Dia. Hose Coupler | 1 |

* 4, 1 gallon bottles

Clarke®
BEXT®-150H, 120V
Wiring Diagram 10/01



10/04/01