IVIE Enterprises

www.ivie-ent.com

Ph:(918)254-5161 or (888)262-5161 Fax:(918)250-4807



C2K Series

120V

Section II

Parts and Service Manual

(70152A)

MAINTENANCE

 **WARNING: Maintenance must be done by authorized personnel only.**

 **CAUTION: Keep all adjustments according to specifications.**

Maintenance Instructions

Return the machine to a Clarke Technology Authorized Service Location every 12 months for maintenance inspections.

Switches

 **WARNING: All electrical repairs must be done by authorized personnel only. The machine must be tested after electrical repairs to make sure it is safe to operate. Disconnect the electrical plug from the electrical outlet before doing any electrical repairs.**

The start and stop switch has an interlock which prevents the contacts from being closed. If any part of the switch is not operating, replace the part. If any part of the electrical system of the machine is not operating or is damaged, replace the part. Make sure all connections are tight. Return the machine to the Clarke Technology Service Branch or a Clarke Technology Authorized Service Center for electrical repairs or testing.

Maintenance Of The Motor

Induction type motors do not require motor brushes. C2K-1600DS and C2K-2000DS require motor brushes.

If repairs to the gear unit or motor are needed, do not disassemble the gears and motor. Return the machine to the nearest Clarke Technology Service Branch or Clarke Technology Authorized Service Center.

For safe operation, and longer life to your Clarke Technology product, use only Clarke Technology parts.

NOTE: The grease (503802) for the gear box needs to be changed every year. The C2K-1600, C2K-1600DS, C2K-1800, C2K-2000 and C2K-2000DS require 8 oz. of grease. All other C2K series require 9 oz. of grease.

IVIE Enterprises

www.ivie-ent.com

Ph:(918)254-5161 or (888)262-5161 Fax:(918)250-4807

CLARKE TECHNOLOGY
C2K-16, C2K-18, C2K-160, C2K-180, C2K-200,
C2K-1600, C2K-1800, C2K-2000, C2K-160HS, C2K-180HS, C2K-200HS
Assembly Drawing 2/01

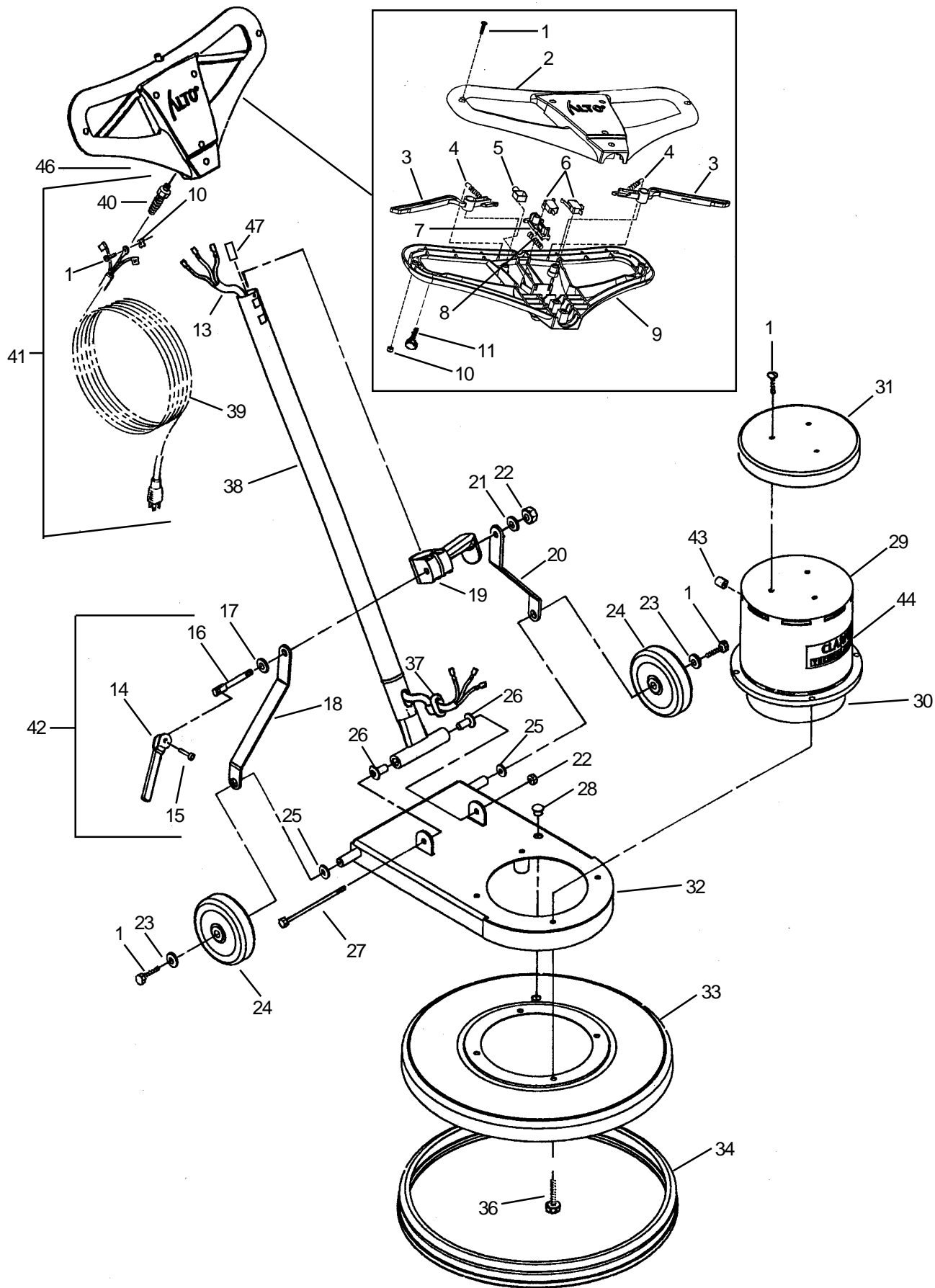

CLARKE TECHNOLOGY
C2K-16, C2K-18, C2K-160, C2K-180, C2K-200,
C2K-1600, C2K-1800, C2K-2000, C2K-160HS, C2K-180HS, C2K-200HS
Assembly Drawing Parts List 2/01

Ref.	Part No.	Description	Qty.
1	85383A	Screw, 10-32 x 3/4	10
2	50779A	Handle, Front	1
3	50798A	Lever, Switch	2
4	50820A	Spring, Extension	2
5	50806A	Button, Interlock	1
6	40109A	Switch	2
7	50799A	Interlock, Main	1
8	50821A	Spring, Compression	1
9	50780A	Handle, Rear	1
10	920722	Nut, 10-32 ESNA	7
11	962957	Screw	2
13	10092A	Cord, Interconnect	1
14	461404	Cam, Locking (included in 42)	1
15	925592	Roll Pin, 1/4 (included in 42)	1
16	441301	Bolt, Locking Cam (included in 42)	1
17	980349	Washer, Wear Cam	1
18	50791A	Arm Link, RH	1
19	50781A	Clamp, Handle	1
20	50792A	Arm Link, LH	1
21	980645	Washer, Flat 3/8	1
22	920342	Nut, 3/8 -16 ESNA	2
23	87035A	Washer, Fender #10 SS	2
24	50793A	Wheel, 5"	2
25	87050A	Washer, 5/8 Nylon	2
26	50794A	Bushing, Nylon	2
27	80087A	Screw, 3/8 -16 x 6	1
28	57120A	Plug, Button	1
29	50955A	Motor, 3/4 HP (16, 18)	1
30	44635A	Motor, 1 HP (160, 180, 200)	1
	50858B	Motor, 1.5 HP (1600)	1
	50858A	Motor, 1.5 HP (1800, 2000)	1
	54409A	Gearbox (16, 18, 160, 180, 200)	1
31	52093A	Gearbox (160HS, 180HS, 200HS)	1
	50851A	Gearbox (1600, 1800, 2000)	1
	50822A	Cover, Motor (16, 18, 160, 180, 200, 160HS, 180HS, 200HS)	1
32	50823A	Cover, Motor (1600, 1800, 2000)	1
	50790A	Frame, Main	1
	50785A	Shield, Brush (16, 160, 1600)	1
	50786A	Shield, Brush (18, 180, 1800)	1
	50787A	Shield, Brush (200, 2000)	1
	50782A	Bumper, (16, 160, 1600)	1
34	50783A	Bumper, (18, 180, 1800)	1
	50784A	Bumper, (200, 2000)	1
	50784A	Bumper, (200, 2000)	1
36	85817A	Screw, 5/16-18 x 2 1/8	4
37	50796A	Bushing, Cord	1
38	50795A	Tube, Handle	1
40	50797A	Relief, Strain (included w/41)	1
41	10083A	Cord Assembly (includes 40)	1
42	441401	Cam Assembly (incl. 14, 15 & 16)	(1)
43	747553	Strain Relief	1
44	77378A	Label	1
45	980603	Lockwasher #10	1
46	170686	Lock nut (not illustrated)	1
47	50930A	Cord Retainer	1

Note: ◆ indicates a change has been made since last publication of this manual

CLARKETECHNOLOGY
 C2K-1600DS and C2K-2000DS
 Assembly Drawing 2/01

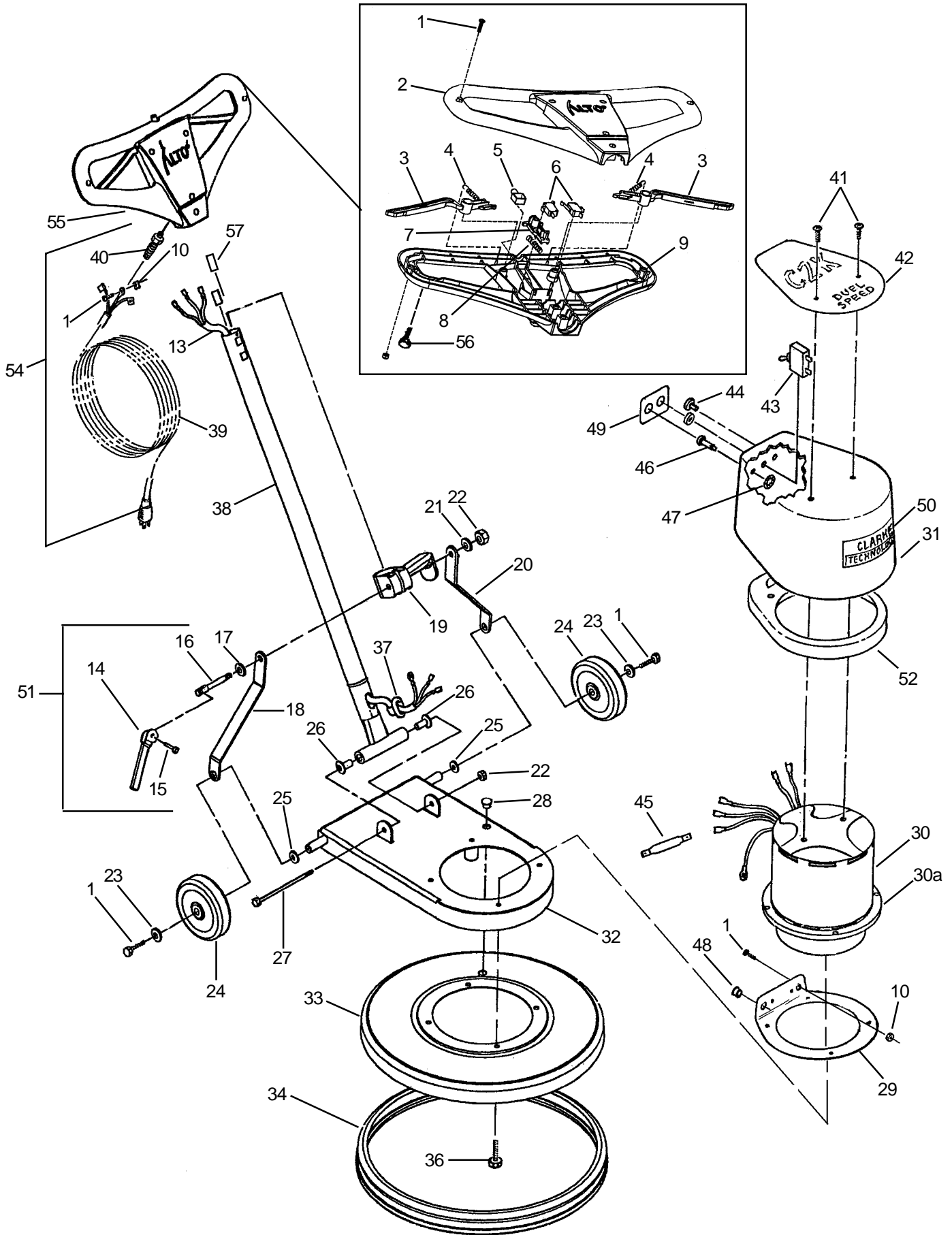

CLARKETECHNOLOGY
C2K-1600DS and C2K-2000DS
Assembly Parts List 2/01

Ref.	Part No.	Description	Qty.
1	85383A	Screw, 10-32 x 3/4	8
2	50779A	Handle, Front	1
3	50798A	Lever, Switch	2
4	50820A	Spring, Extension	2
5	50806A	Button, Interlock	1
6	40109A	Switch	2
7	50799A	Interlock, Main	1
8	50821A	Spring, Compression	1
9	50780A	Handle, Rear	1
10	920722	Nut, 10-32 ESNA	8
13	10084A	Cord, Interconnect	1
14	461404	Cam, Locking (Included in 51)	1
15	925592	Roll Pin, 1/4 (Included in 51)	1
16	441301	Bolt, Locking Cam (included in 51)	1
17	980349	Washer, Wear Cam	1
18	50791A	Arm Link, RH	1
19	50781A	Clamp, Handle	1
20	50792A	Arm Link, LH	1
21	980645	Washer, Flat 3/8	1
22	920342	Nut, 3/8 -16 ESNA	2
23	87035A	Washer, Fender #10 SS	2
24	50793A	Wheel, 5"	2
25	87050A	Washer, 5/8 Nylon	2
26	50794A	Bushing, Nylon	2
27	80087A	Screw, 3/8 -16 x 6	1
28	57120A	Plug, Button	1
29	50825A	Bracket	1
30	44651A	Motor/Gearbox	1
30a	63602A	Gearbox	(1)
31	50824A	Cover, Motor	1
32	50790A	Frame, Main	1
33	50785A	Shield, Brush (1600)	1
	50787A	Shield, Brush (2000)	1
34	50782A	Bumper, (1600)	1
	50784A	Bumper, (2000)	1
36	85817A	Screw, 5/16-18 x 2 1/8	4
37	50796A	Bushing, Cord	1
38	50795A	Tube, Handle	1
40	50797A	Relief, Strain (included w/54)	1
41	85517A	Screw	2
42	70151A	Label, Dual Speed	1
43	47402B◆	Switch SPDT	1
44	57165A◆	Plug, Nylon Hole	1
45	40181A◆	Insulated Jumper	1
46	34259A	Light	1
47	80201A	Clip	1
48	747553	Strain Relief	1
49	77200A	Label, (High-Low)	1
50	77378A	Label	1
51	441401	Cam Assembly (incl. 14, 15, & 16)	(1)
52	30605A	Baffle	1
54	10083A	Cord Assembly (includes 40)	1
55	170686◆	Locknut	1
56	962957	Screw	1
57	50930A	Cord Retainer	1

Note: ◆ indicates a change has been made since last publication of this manual

IVIE Enterprises

www.ivie-ent.com Ph:(918)254-5161 or (888)262-5161 Fax:(918)250-4807

CLARKE TECHNOLOGY
C2K-16, C2K-18, C2K-160, C2K-180, C2K-200, C2K-160HS, C2K-180HS and C2K-200HS
120V - 60 Hz Motor Assembly Drawing & Parts List 9/99

Note: If your machine has motor #44635A refer to this drawing for service part replacement.

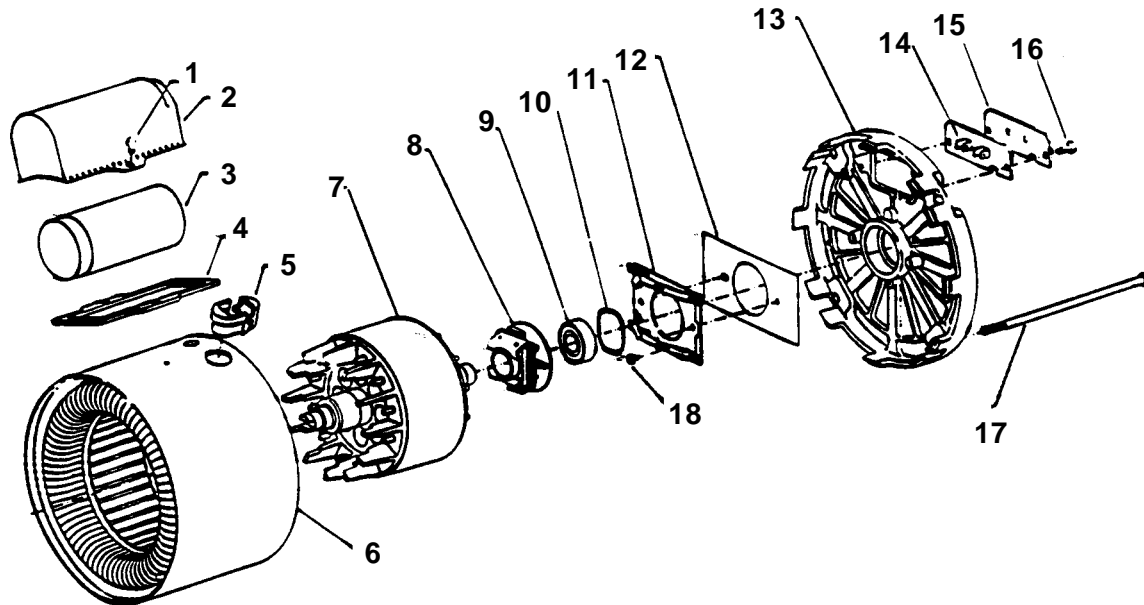

Ref.	Part No.	Description	Qty.	Ref.	Part No.	Description	Qty.
1	58030A	Screw #10-32 x.31 LG.	2	10	58673A	Wave Spring Washer	1
2	52018A	Capacitor Case	1	11	58032A	Stationary Switch	1
3	52019A	Start Capacitor	1	12	54713A	Stationary Switch Insulation	1
4	54330A	Gasket, Capacitor Case	1	13	53523A	Bracket Opp. Shaft End	1
5	737502	Strain Relief	1	14	58911A	Terminal Board Asm.	1
6	58028A	Stator Frame Asm	1	15	58912A	Terminal Board	1
7	50400A	Rotor and Shaft Assembly	1	16	58034A	Screw #10-32 x .31	2
8	58029A	Centrifugal Switch Asm.	1	17	50691A	Bolt, .250-28 x 6.75 LG	4
9	902550	203 Bearing	1	18	58031A	Screw, #8-32 x .38 LG	2

**120V Motor
Electrical Schematic**

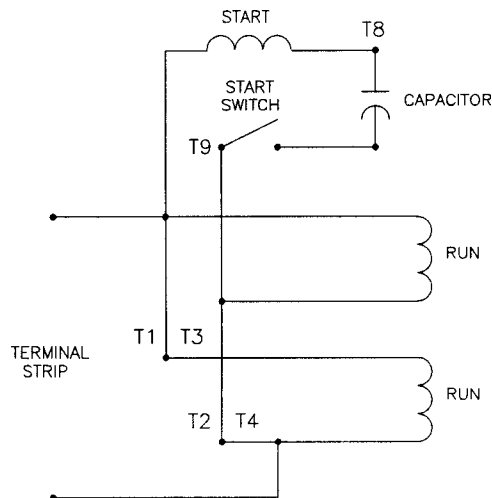

CLARKE TECHNOLOGY
C2K-16, C2K-18, C2K-160, C2K-180 and C2K-200
Gearbox Assembly Drawing & Parts List 2/01

Note: If your machine has gearbox #54409A refer to this drawing for service part replacement.

Note: ♦ indicates a change has been made since last publication of this manual

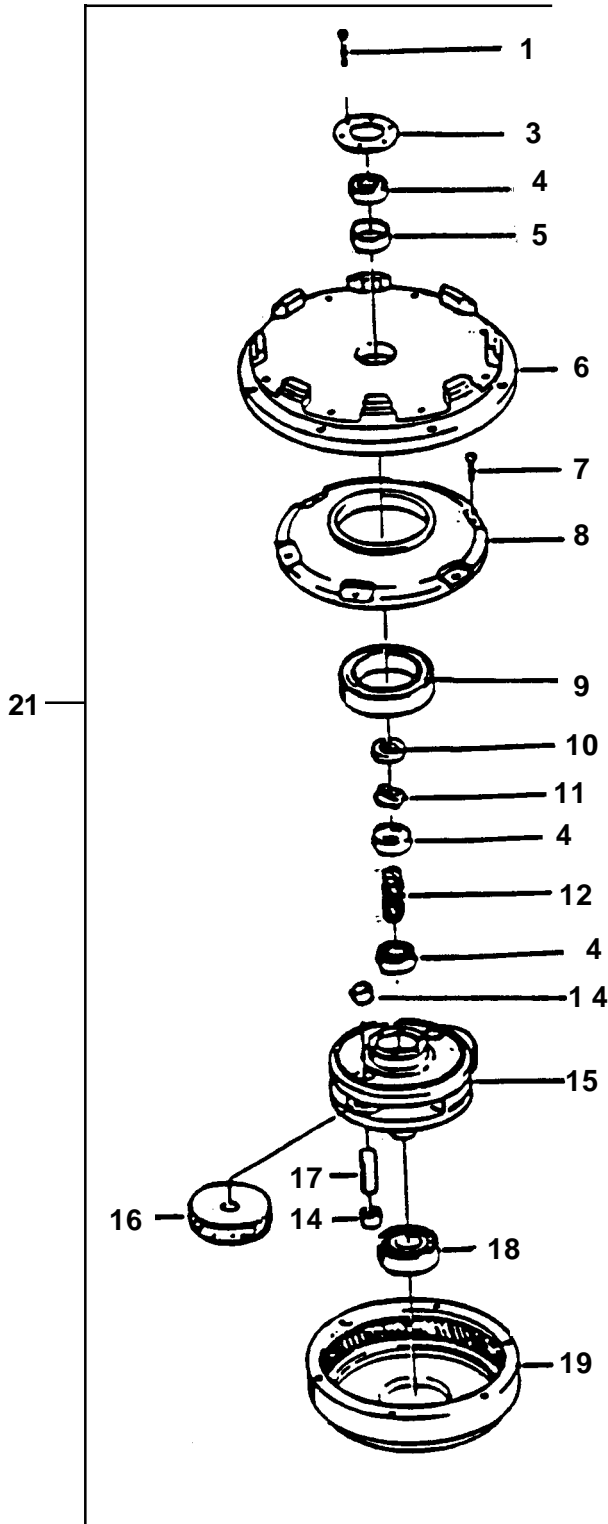

Ref.	Part No.	Description	Qty.
1	80141A ♦	Screw, Socket Hd. Cap	6
2			
3	56922A	Plate, Retainer	1
4	902606	Bearing	3
5	58513A	Spacer, Sleeve	1
6	53524A	Endshield	1
7	962794	Screw 10-24" x 1"	6
8	54858A	Cover, Housing	1
9	902736	Bearing	1
10	58314A	Retainer	1
11	442473	Coupling	1
12	58313A	Gear, Pinion	1
14	902737	Bearing, Needle	6
15	52020A	Cage	1
16	54408A	Gear, Idler	2
17	58312A	Shaft	2
18	902573	Bearing	1
19	54856A	Housing, Drive	1
20			
21	54409A	Gearbox Asm., Complete	(1)

IVIE Enterprises

www.ivie-ent.com Ph:(918)254-5161 or (888)262-5161 Fax:(918)250-4807

CLARKETECHNOLOGY
C2K-160HS, C2K 180HS and C2K 200HS
Gearbox Assembly Drawing & Parts List 2/00

Note: If your machine has gearbox #50884A or #52093A refer to this drawing for service part replacement.

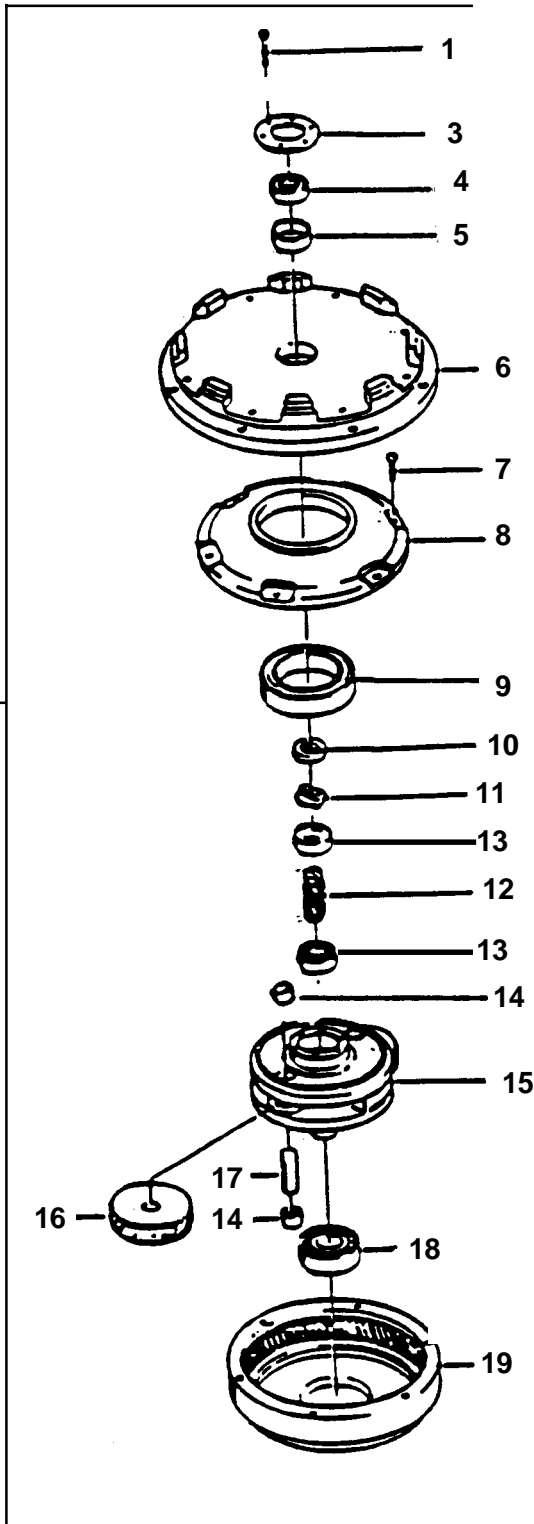

Note: ♦ indicates a change has been made since the last publication of this manual.

Ref.	Part No.	Description	50884A Qty.	52093A Qty.
1	80141A♦	Screw, Socket Hd. Cap	6	6
2				
3	56922A	Plate, Retainer	1	1
4	902606	Bearing	1	1
5	58513A	Spacer, Sleeve	1	1
6	53524A	Endshield	1	1
7	962794	Screw 10-24" x 1"	6	6
8	54858A	Cover, Housing	1	1
9	902736	Bearing	1	1
10	58314A	Retainer	1	1
11	442473	Coupling	1	1
12	50887A	Gear, Pinion	1	-
	50854A	Gear, Pinion	-	1
13	902606	Bearing	-	2
14	902737	Bearing, Needle	4	4
15	50886A	Cage	1	-
	50855A	Cage	-	1
16	50888A	Gear, Idler	2	-
	50856A	Gear, Idler	-	2
17	58312A	Shaft	2	2
18	902573	Bearing	1	1
19	50857A	Housing, Drive	1	1
20	52093A	Gearbox Asm., Complete	-	(1)
	50884A	Gearbox Asm., Complete	(1)	-

IVIE Enterprises

www.ivie-ent.com Ph:(918)254-5161 or (888)262-5161 Fax:(918)250-4807

CLARKE TECHNOLOGY
C2K-1600, C2K-1800, C2K-2000
Motor Assembly Drawing & Parts List 9/00

Note: If your machine has motor #50858A or #50858B refer to this drawing for service part replacements.

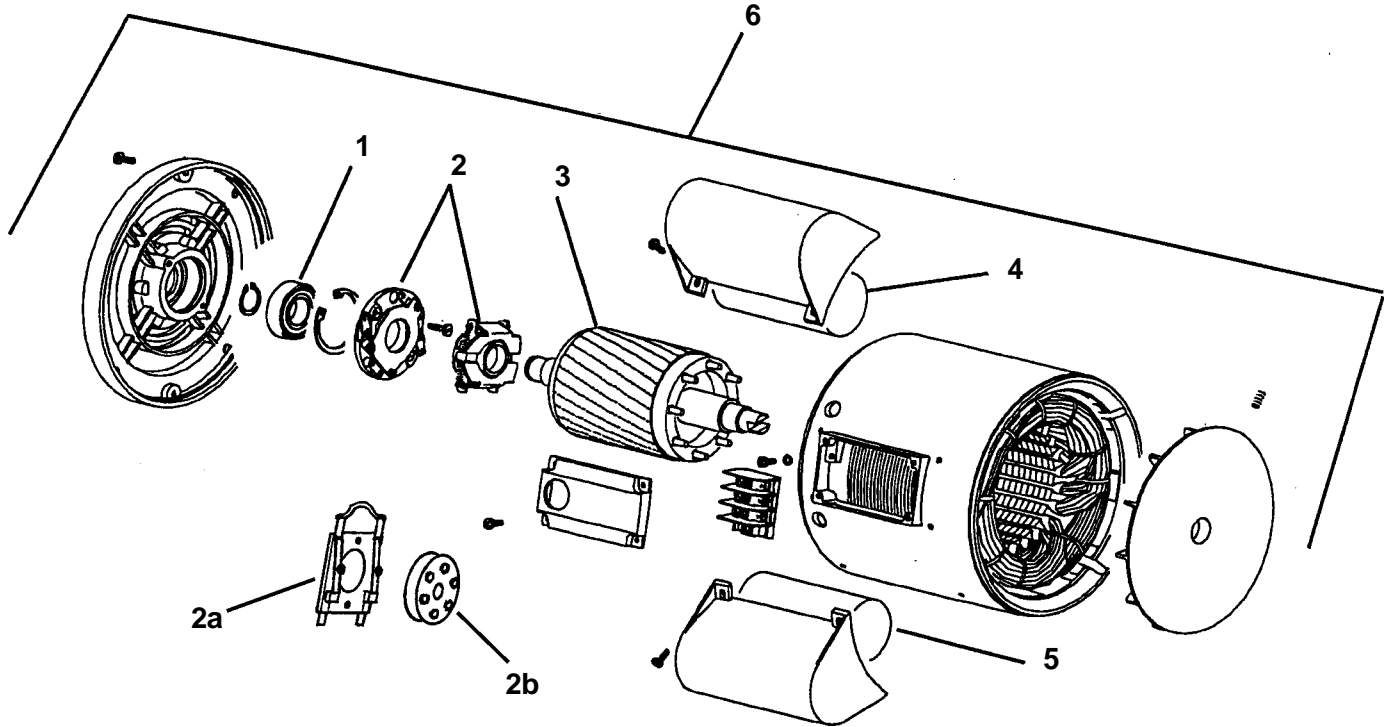

Ref.	50858A Part #'s	50858B Part #'s	Description	Qty
1	50861A	50861A	Ball Bearing	1
2	50860A		Centrifugal Switch	1
2(a)		51072A	Stationary Switch	1
2(b)		51070A	Centrifugal Mechanism	1
3	50859A	51073A	Rotor	1
4	50862A	50862A	Capacitor, Start	1
5	50863A	50863A	Capacitor, Run	1
6	50858A	50858B	Motor, Complete	(1)

**120V Motor
 Connection Diagram**

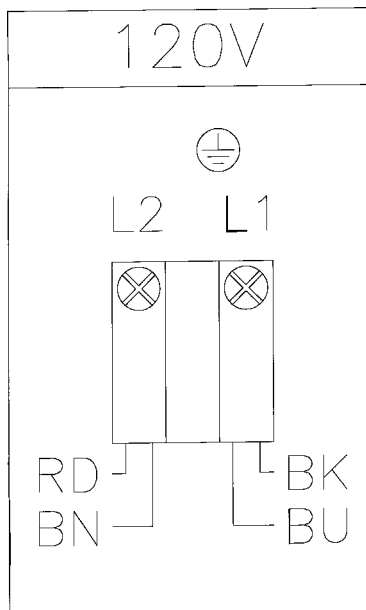

CLARKE TECHNOLOGY
C2K-1600, C2K-1800, C2K-2000
Gearbox Assembly Drawing & Parts List 2/01

NOTE: If your machine has gearbox #50851A, refer to this drawing for service part replacement.

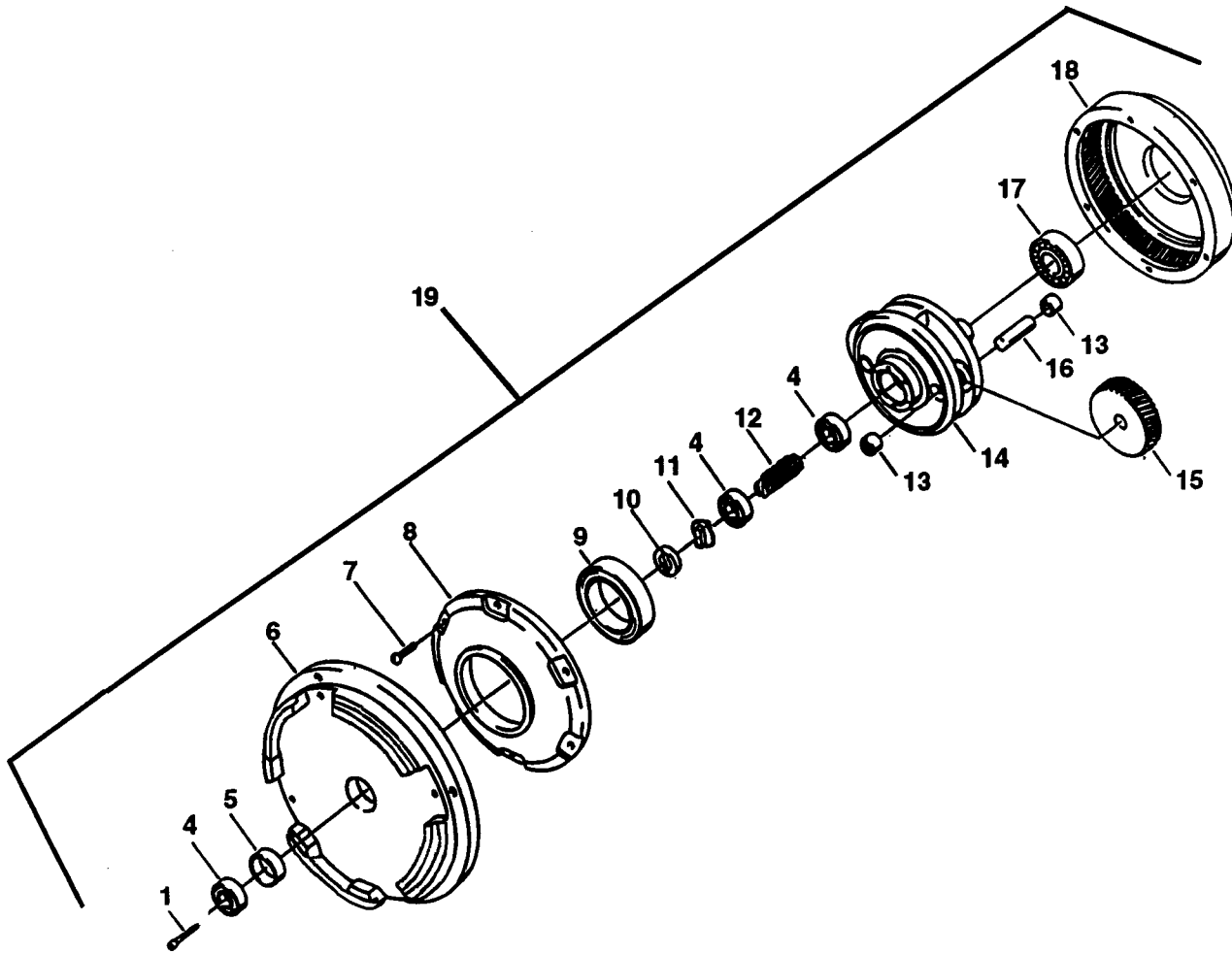

Note: ♦ indicates a change has been made since last publication of this manual

Ref	Part No.	Description	Qty.
1	80141A ♦	Screw, Socket Hd. Cap	6
4	902606	Bearing, Ball	3
5	58520A	Spacer, Sleeve	1
6	50852A	Endshield	1
7	962794	Screw #10-24 x 1"	6
8	54858A	Cover, Housing	1
9	902736	Bearing	1
10	58314A	Retainer	1
11	442473	Coupling	1
12	58313A	Gear, Pinion	1
13	902737	Bearing, Needle	6
14	N/A	Cage	1
15	54408A	Gear, Idler	3
16	58312A	Shaft	3
17	902573	Bearing, Ball	1
18	54856A	Housing, Drive	1
19	50851A	Gearbox Asm., Complete	(1)

IVIE Enterprises

www.ivie-ent.com Ph:(918)254-5161 or (888)262-5161 Fax:(918)250-4807

CLARKE TECHNOLOGY
C2K-1600DS and C2K-2000DS
120V Motor Assembly Drawing & Parts List 2/01

NOTE: If your machine has motor/gearbox #44651A, refer to this drawing for service part replacement.

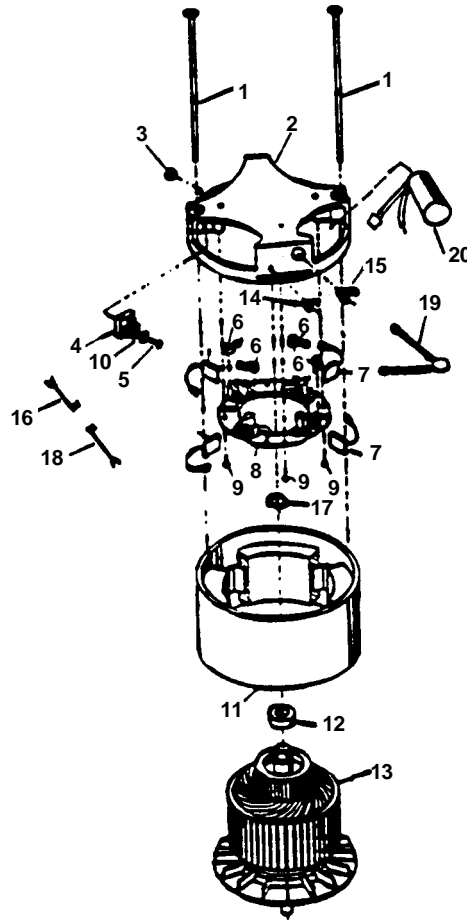

Note: ◆ indicates a change has been made since last publication of this manual

Ref	Part No.	Description	Qty.
1	50717A	Thru-Bolt	2
2	N/A	Commutator Bracket	1
3	56282A	Hex Nut	1
4	912287	Rectifier	1
5	962399	Screw	1
6	448396	Spring (Included with #8)	(4)
7	51405A	Brush Asm., (Included w/#8)	(4)
8	40410A◆	Brush Board Asm. (incl #'s 6,7,16, 18,19)	1
9	962310	Screw	4
10	980608	#8 Flat Washer	1
11	58057A	Stator Frame	1
12	902550	Bearing-Upper (Included w/#13)	(1)
13	40322A	Armature Asm. (Includes #12)	1
14	N/A	Strain Relief	1
15	N/A	Bushing	1
16	55648A	Red Lead (Included with #8)	1
17	980076	Wave Washer	1
18	55647A	Yellow Lead (Included with #8)	1
19	59606A	Varistor (Included w/#8)	(1)
20	46735A	Speed Control	1

CLARKETECHNOLOGY
C2K-1600DS and C2K-2000DS
Gearbox Assembly Drawing & Parts List 2/01

NOTE: If your machine has gearbox #63602A, refer to this drawing for service part replacement.

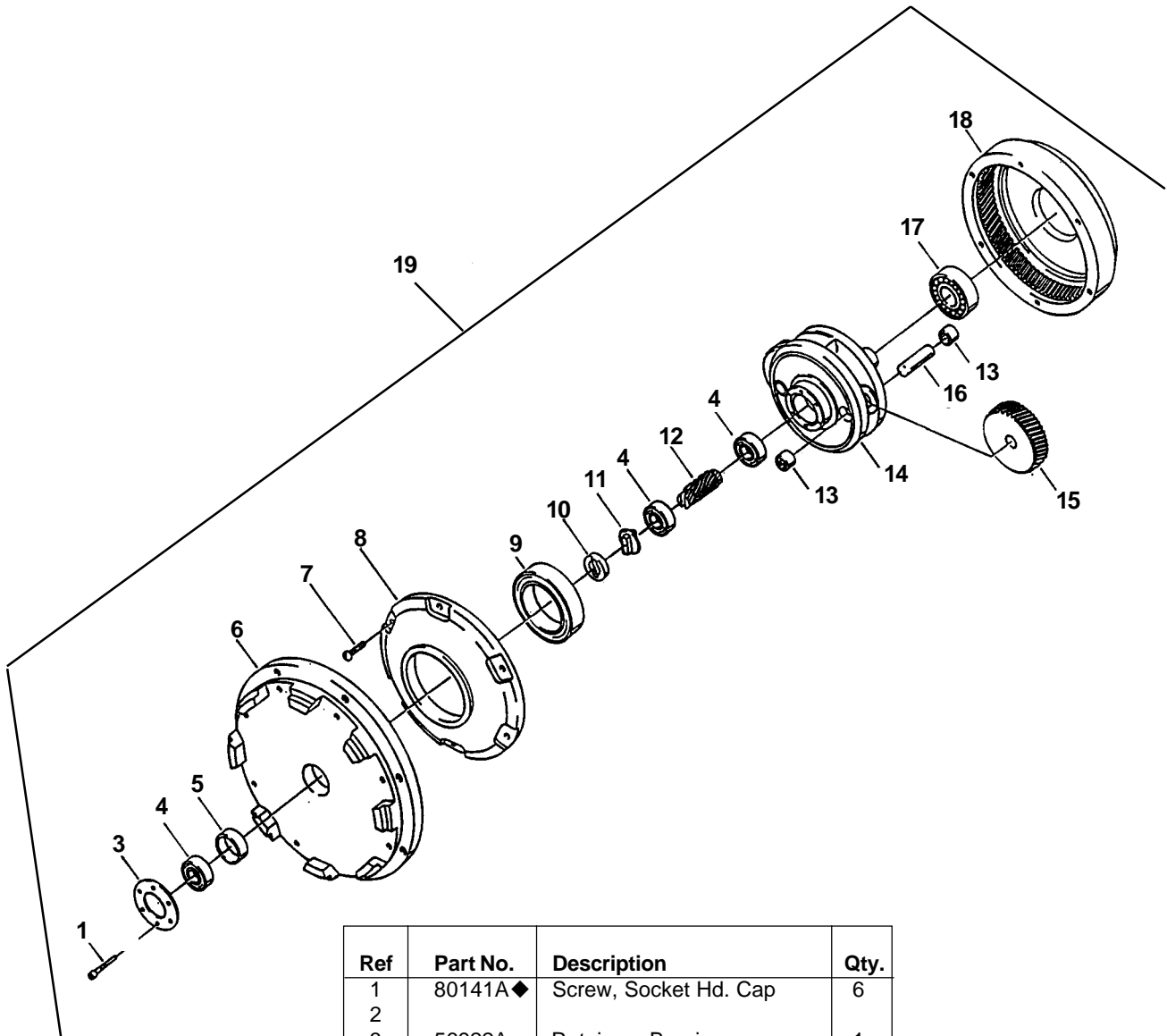

Note: ◆ indicates a change has taken place since last publication of this manual

Ref	Part No.	Description	Qty.
1	80141A◆	Screw, Socket Hd. Cap	6
2			
3	56922A	Retainer, Bearing	1
4	902606	Bearing, Ball	3
5	58520A	Spacer, Sleeve	1
6	53539A	Endshield	1
7	962794	Screw 10-24" x 1"	6
8	54858A	Cover, Housing	1
9	902736	Bearing	1
10	58314A	Retainer	1
11	442473	Coupling	1
12	58313A	Gear, Pinion	1
13	902737	Bearing, Needle	6
14	N/A	Cage	1
15	54408A	Gear, Idler	3
16	58312A	Shaft	3
17	902573	Bearing, Ball	1
18	54856A	Housing, Drive	1
19	63602A	Gearbox Asm., Complete	(1)

CLARKETECHNOLOGY
C2K-16, C2K-18, C2K-160, C2K-180, C2K-200,
C2K-1600, C2K-1800, C2K-2000, C2K-160HS, C2K-180HS, C2K-200HS
Wiring Diagram 120V-60Hz 9/99

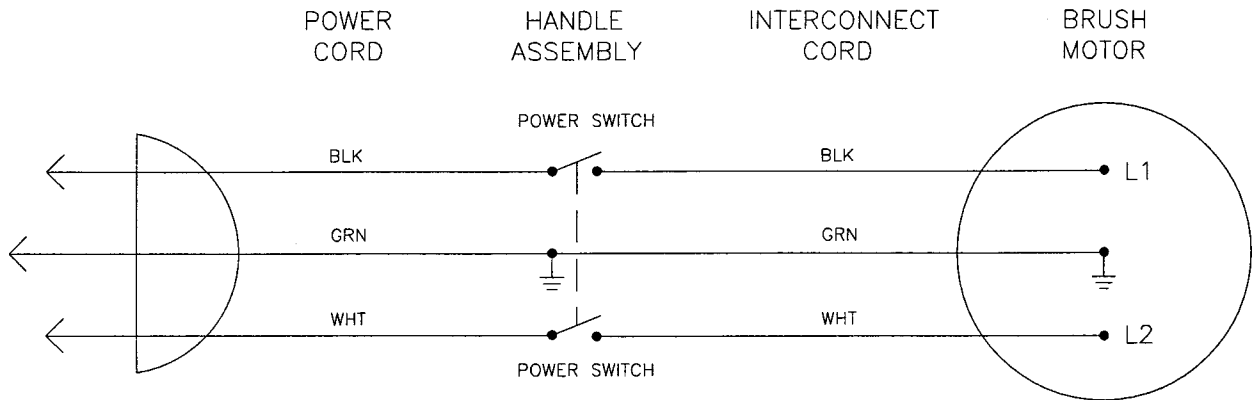

CLARKETECHNOLOGY
C2K-1600DS and C2K-2000DS
Wiring Diagram 120V 9/99

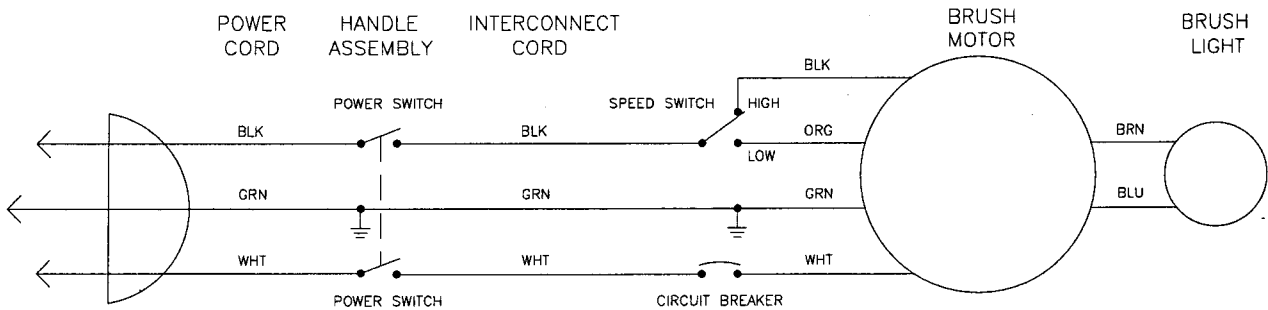

⚠ WARNING: All electrical repairs must be performed by qualified personnel only.

IVIE Enterprises
www.ivie-ent.com Ph:(918)254-5161 or (888)262-5161 Fax:(918)250-4807