

Clarke®

Operator's Manual

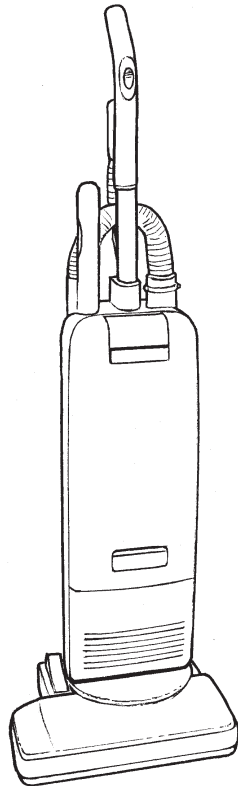

D14 & D18 Upright Vacuum

READ THIS BOOK

This book has important information for the use and safe operation of this machine. Failure to read this book prior to operating or attempting any service or maintenance procedure to your Clarke machine could result in injury to you or to other personnel; damage to the machine or to other property could occur as well. You must have training in the operation of this machine before using it. If your operator(s) cannot read English, have this manual explained fully before attempting to operate this machine.

Si Ud. o sus operadores no pueden leer el Inglés, se hagan explicar este manual completamente antes de tratar el manejo o servicio de esta máquina.

All directions given in this book are as seen from the operator's position at the rear of the machine.

For new books write to: Clarke®, 2100 Highway 265, Springdale, Arkansas 72764.

Table of Contents

Important Safety Instructions	3
Introduction & Machine Specifications	7
Grounding Instructions	8
How To Assemble The Machine	9
The Controls	12
How To Operate The Machine	14
Maintenance	15
How To Change The Filter Bag	15
How To Clean The Filter Cartridge	16
How To Replace The Brush	16
How To Change The Drive Belt	17
The Vacuum Indicator Light	17
The Circuit Breaker	17
Brush Performance Indicator Lights	18
 SECTION II Parts and Service Manual	
Drawing #1 Upper Canister Assembly	20
Parts List #1 Upper Canister Assembly	21
Drawing #2 Brush Housing Assembly	22
Parts List #2 Brush Housing Assembly	23
Parts List #3 Hose Wand and Handle Assembly	24

IMPORTANT SAFETY INSTRUCTIONS



WARNING



AVERTISSEMENT



ADVERTENCIA

For the safe operation of this machine, read and understand all dangers, warnings and cautions. Look for these symbols:

DANGER:	If you do not follow the instructions in a DANGER , severe bodily injury or death can occur to the operator and/or other personnel.
WARNING:	If you do not follow the instructions in a WARNING , injury can occur to you or to other personnel.
CAUTION:	If you do not follow the instructions in a CAUTION , damage can occur to the machine.

 **WARNING:** To reduce the risk of fire, electric shock, or injury:

1. You must have training in the operation of this machine before using it. READ THE INSTRUCTION BOOK.
2. Do not use outdoors or on wet surfaces.
3. Do not leave vacuum cleaner unattended when plugged in. Turn off the switch and unplug the electrical cord when not in use and before servicing.
4. Do not allow to be used as a toy. Close attention is necessary when used by or near children.
5. Use only as described in this manual. Use only manufacturer's recommended attachments.
6. Do not use with damaged cord or plug. If vacuum cleaner is not working as it should, has been dropped, damaged, left outdoors, or dropped into water, return it to a service center.
7. Do not pull or carry by cord, use cord as a handle, close a door on cord, or pull a cord around sharp edges or corners. Do not run vacuum cleaner over cord. Keep cord away from heated surfaces.
8. Connect to a properly grounded outlet only (refer to Grounding Instructions).
9. Do not use extension cords or outlets with inadequate current carrying capacity.
10. Turn off all controls before unplugging.
11. Do not unplug by pulling on cord. To unplug, grasp the plug, not the cord.
12. Do not handle plug or vacuum cleaner with wet hands.
13. Do not put any objects into openings. Do not use with any opening blocked, keep free of dust, lint, hair, and anything that may reduce airflow.
14. This vacuum cleaner creates suction and contains a revolving brush. Keep hair, loose clothing, fingers and all parts of body away from openings and moving parts.
15. Do not pick up anything that is burning or smoking, such as cigarettes, matches or hot ashes.

▲ WARNING: To reduce the risk of fire, electric shock, or injury:

16. Belt pulleys can become hot during normal use. To prevent burns, avoid touching the belt pulley when servicing the drive belt.
17. Do not use to pick up flammable or combustible liquids such as gasoline, or use in areas where they may be present.
18. Unplug the machine before servicing the belt or brush. The brush may start suddenly and cause injury.

SAVE THESE INSTRUCTIONS

INTRODUCTION



The D14 and D18 are upright vacuums for cleaning carpet. These machines are used to remove dry material from carpet. These machines are intended for commercial use.

MACHINE SPECIFICATIONS

Model	D14	D18
Power Supply	120V-60 Cycle 230V-50/60 Cycle	120V-60 Cycle 230V-50/60 Cycle
Vacuum Motor	1050 Watts	1050 Watts
Brush RPM	4300 rpm	4300 rpm
Cord	50 ft. 3-wire	50 ft. 3-wire
Wheels (2)	2.7" x 1.25"	2.7" x 1.25"
Wand	21" extends to 33.5"	21" extends to 33.5"
Hose	1.5" x 18.5" extends to 72"	1.5" x 18.5" extends to 72"
Agitator Brush	Chevron Brush Pattern	Chevron Brush Pattern
Cleaning Width	14"	18"
Filter Bags	6 lt, 2-ply disposable	6 lt, 2-ply disposable
Weight (less power cord)	20 lbs.	20.5 lbs.
Shipping Weight	26 lbs	26.75 lbs
Vacuum Dimensions	10.5 x 14.25 x 46.5	10.5 x 14.25 x 46.5
Warranty	One Year	One Year

GROUNDING INSTRUCTIONS

Preparation:

The following are instructions for connection to the power supply and the electrical ground.

This machine must be connected to the electrical ground to protect the operator from electrical shock. The machine has an approved power cord with three conductors and a plug with three terminals. Connect the plug to a receptacle that has three holes and is connected to the electrical ground. The green (or green and yellow) conductor in the cord is the ground wire. Never connect this wire to any terminal other than the ground pin terminal.

⚠ DANGER: Improper connection of the equipment-grounding conductor can result in risk of electric shock. Check with a qualified electrician or service person if you are in doubt as to whether the outlet is properly grounded. Do not modify the plug provided with the appliance. If it will not fit the outlet, have a proper outlet installed by a qualified electrician.

This machine is for use on a 110 to 120 Volt AC 60 cycle electric circuit. Make sure you have the correct frequency and voltage before connecting the power cord to an outlet. The machine has a plug as shown in figure A.

⚠ WARNING: Always use this machine with an AC three-conductor electrical system connected to the electrical ground. Replace any worn, cut or damaged cords. Replace any damaged plugs, receptacles or connector bodies.

⚠ WARNING: Do not cut, remove, or break the ground terminal. Do not try to fit a three-terminal plug into a receptacle or connector body that does not fit the plug, see your Authorized Clarke Dealer to get an authorized person to make the connection.

⚠ WARNING: Do not move the machine over an electrical cord. Always lift the cord over the machine.

EXTENSION CORDS:

Use only an approved extension cord with three conductors, a plug with three terminals and a connector body with three holes. This machine has a power cord with wire size 18 AWG (AWG means American Wire Gauge).

⚠ WARNING: If you use an extension cord, use an extension cord with minimum wire size 16 AWG. Do not use an extension cord longer than 50 feet. Do not join two extension cords.

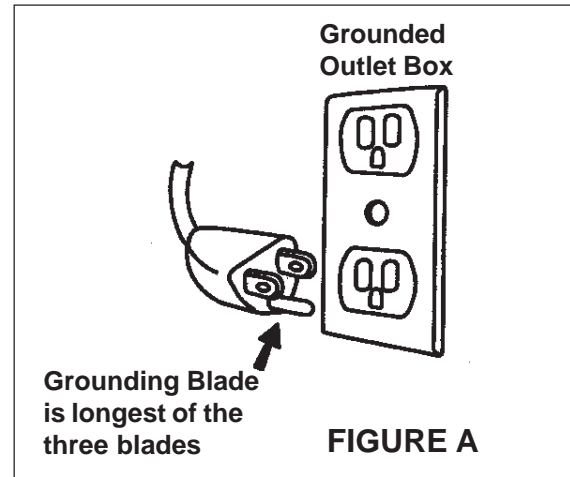

HOW TO ASSEMBLE THE MACHINE

To assemble the machine, follow this procedure:

1. Remove the brush housing, vacuum bags, hose, wand, handle assembly, canister housing, and tools from the carton.
2. Remove the canister housing and the brush housing from the plastic bags.
3. Install the canister housing on the brush housing. To install the canister housing, follow this procedure:
 - a. Position canister housing over brush housing (see figure 2).
 - b. Align pivot airway (A) and canister support pivot (B) with openings (C and D) in bottom of canister housing (see figure 2).
 - c. Lower canister housing completely onto brush housing until pin clicks into place and latches (see figure 3).
4. Install the handle assembly to the canister housing. To install the handle assembly, follow this procedure:
 - a. Insert handle tube in the upper canister housing (see figure 4).
 - b. Lower handle completely into canister housing until mark on handle tube is below flush (see figure 5, item A). This insures the handle is properly seated.
 - c. Push handle latch into lock position (see figure 5, item B).

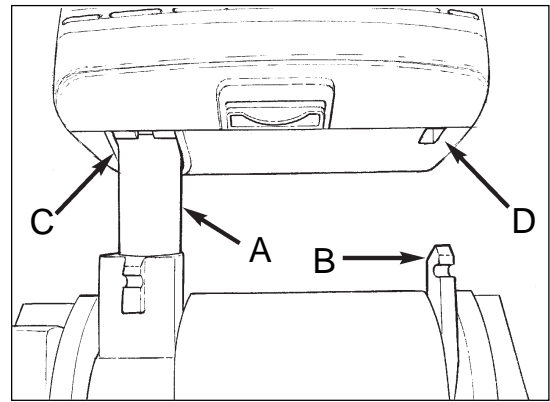

Figure 2

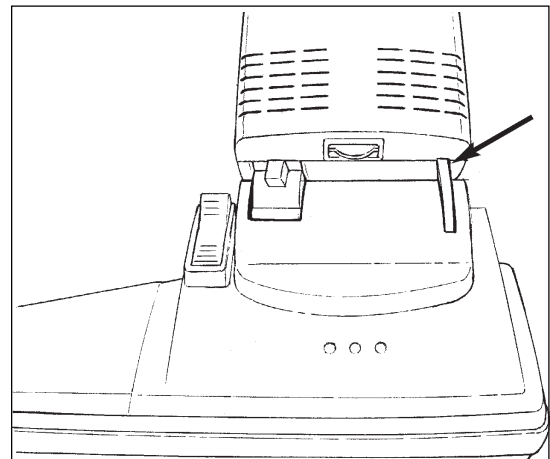

Figure 3

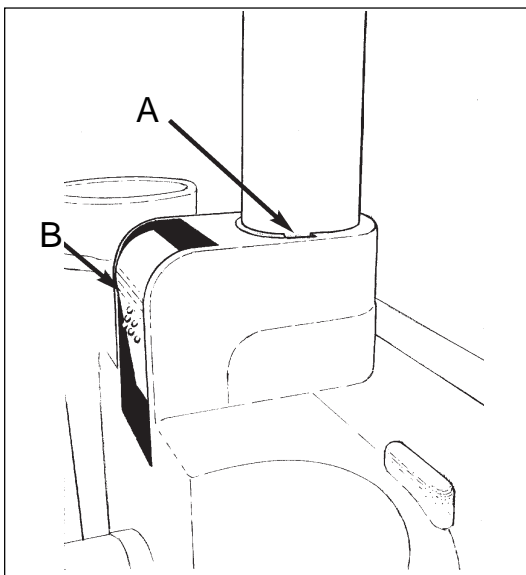

Figure 5

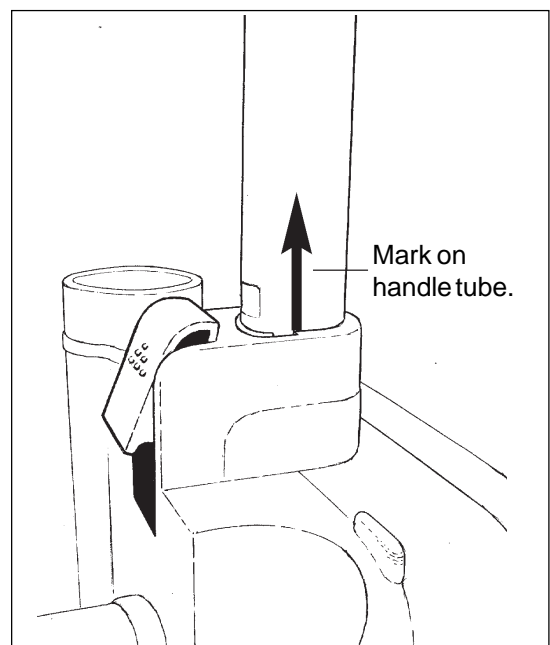

Figure 4

5. Install the wand assembly in the right rear canister housing (see figure 6, item A).
6. Position wand handle so that handle is towards the front of the machine (see figure 7, item A).
7. Attach hose to wand and canister (see figure 7). To attach hose properly, depress lock on canister (see figure 7, item B).
8. Snap the crevice (B) and upholstery (C) tools into the tool retainer on rear of canister housing (see figure 6).

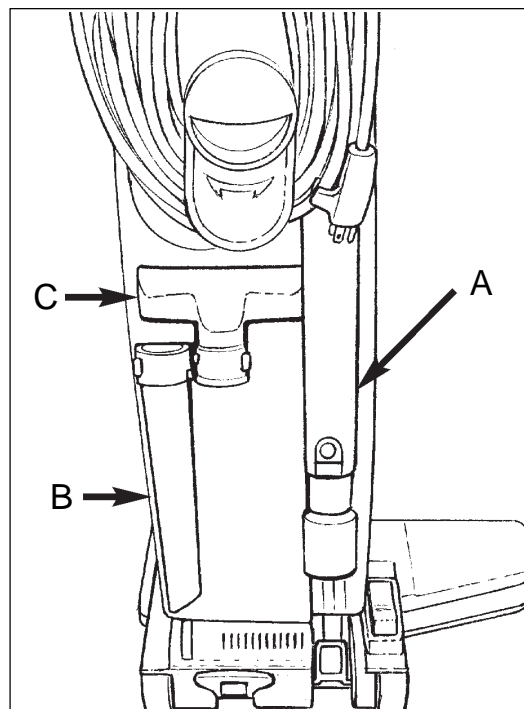

Figure 6

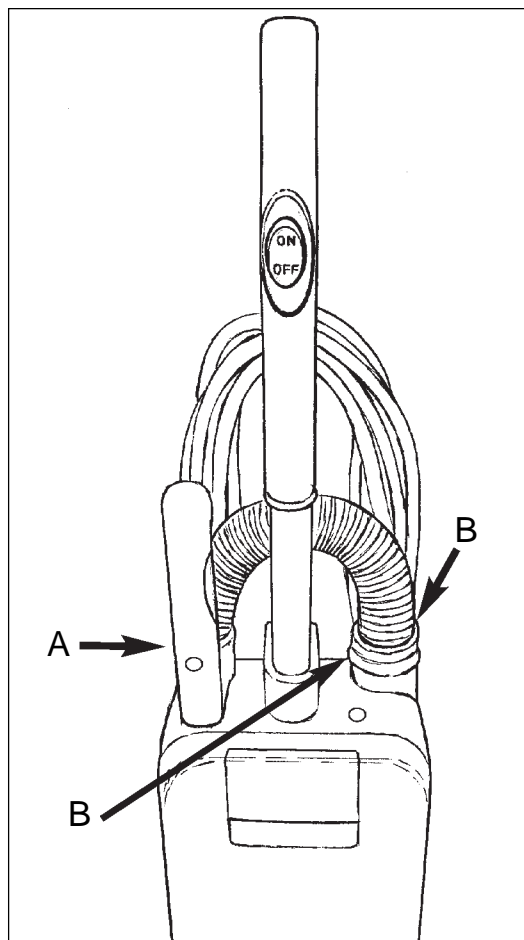

Figure 7

THE CONTROLS

The Handle Release Pedal (See figure 8, item A)

The handle release pedal is on the lower left side of the machine. Press the pedal to release the handle and start the brush motor. The brush motor will not run unless the ON/OFF switch is in the "I" position.

The ON/OFF Switch (See figure 9)

The ON/OFF switch is on handle. Put the switch in the "I" position to start the vacuum motor. Put the switch in the "O" position to stop the vacuum motor. Putting the switch in the off position will also shut off the brush motor.

The Height Adjustment (See figure 8, item B)

The height adjustment is located on the lower right side of the machine. Press the front of the pedal with your foot when vacuuming shorter carpet. Press the back of the pedal with your foot when vacuuming thicker, longer carpet.

The Wand (See figure 8, item C)

The wand is in the holder in the back of the canister housing. The wand has a telescoping feature (see figure 11). The crevice tool and the upholstery tools fit the end of the wand. The wand has a suction control sleeve (see figure 10). For normal vacuuming keep suction control sleeve closed. To reduce suction, when cleaning drapes or furniture, open suction control sleeve.

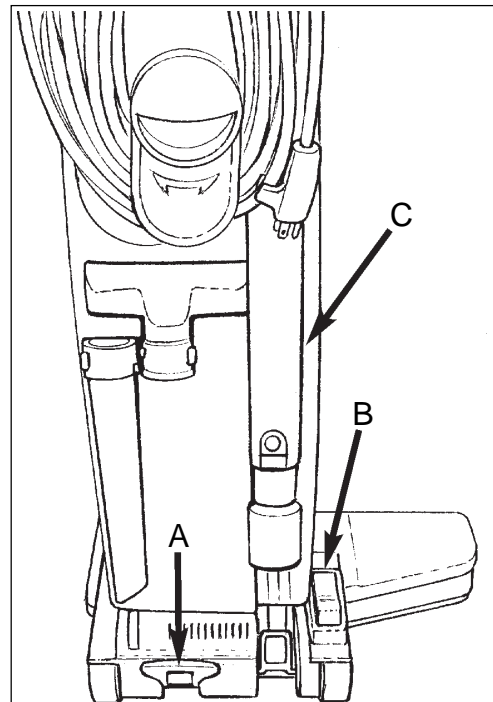

Figure 8

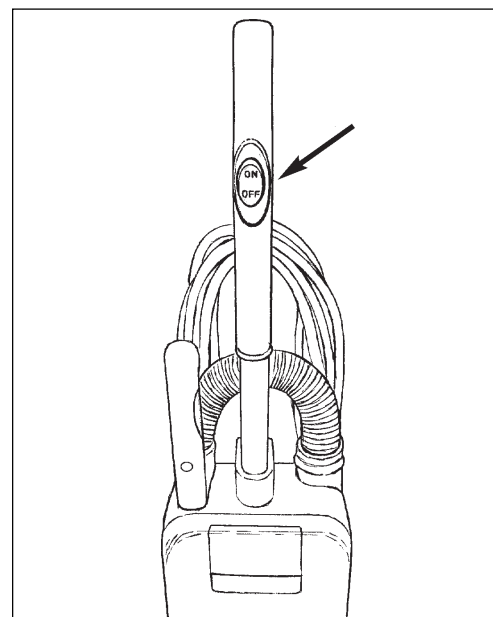

Figure 9

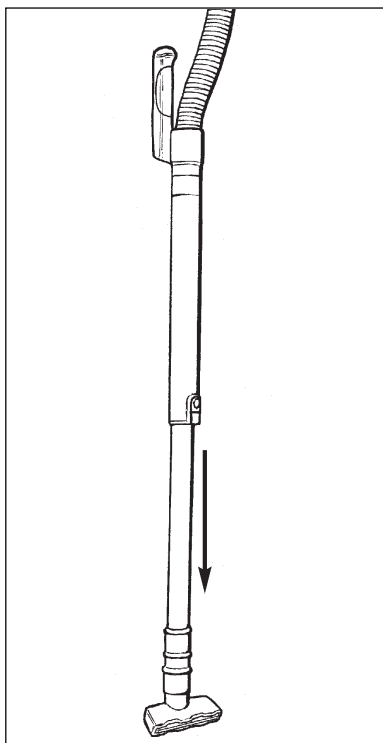

Figure 11

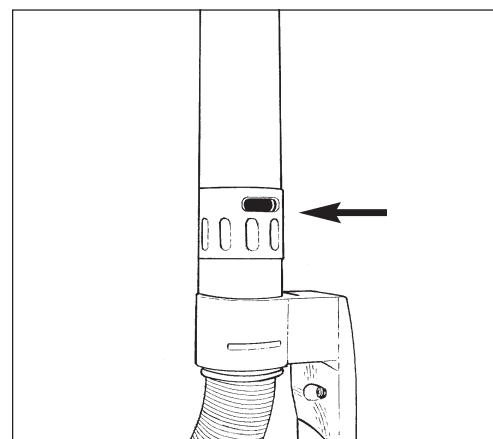

Figure 10

Canister Door (See figure 12, item A)

The canister door release is in the upper part of the canister housing. Lift to open door.

NOTE: Door will not close without a properly mounted filter bag. See page 15 for filter bag mounting instructions.

The Vacuum Indicator Light (See figure 12, item B)

The vacuum indicator light is on the top of the canister housing. The indicator light comes on when the airflow to the vacuum motor is obstructed.

NOTE: See page 17 for instructions on how to remove an obstruction.

The Cord Storage Hooks (See figure 13)

The cord storage hooks are on the back of the canister housing. The lower cord hook is also a carrying handle. The lower cord hook rotates to provide a quick cord release and to ease cord removal.

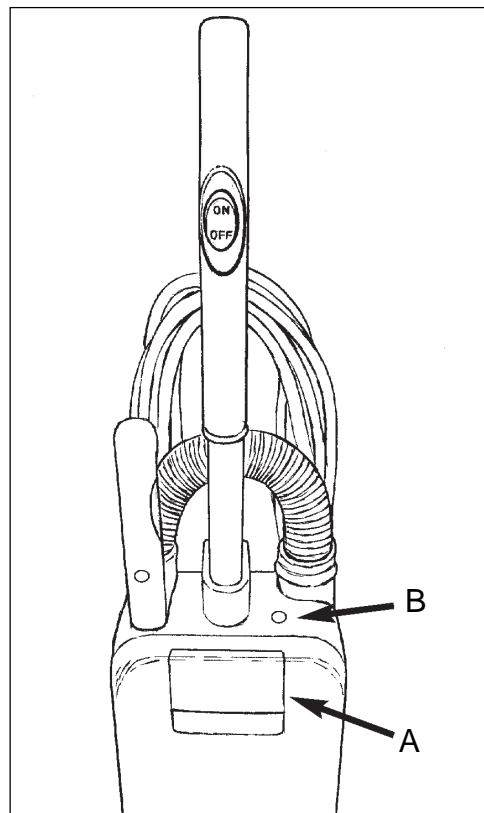

Figure 12

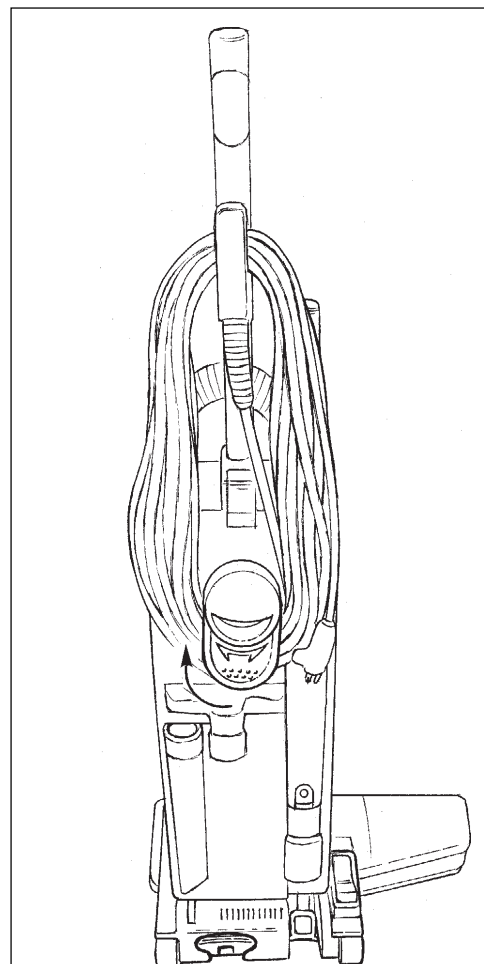

Figure 13

HOW TO OPERATE THE MACHINE

CAUTION: To prevent damage to the machine, do not allow large objects to be pulled into the lower housing or the attachments.

NOTE: The machine comes with a filter bag installed in the canister housing.

Use the D14 & D18 as a carpet cleaner or as an upholstery cleaner. To operate the machine as a carpet cleaner, follow this procedure:

1. Remove the power cord from the cord storage hooks, by rotating the lower cord hook 180° (see figure 14).
2. Connect the electrical plug to the electrical outlet.
3. Put the ON/OFF switch in the "I" position (see figure 9).
4. Press the handle release pedal (see figure 8, item A).
5. Pull the handle toward you to the best operating position.
6. Move the machine forward and backward over the carpet.

To operate the machine as an upholstery cleaner, follow this procedure.

1. Make sure the ON/OFF switch is in the "O" position.
2. Push the handle forward until it locks in position.

NOTE: the machine comes with a crevice tool attachment and an upholstery tool attachment. Select the tool needed for the cleaning operation.

3. Remove the wand from the canister housing.
4. Connect an accessory tool to the end of the wand, or directly to the hose (see figures 15 and 16).

NOTE: Push button on wand handle to release the hose from the wand (see figure 16, item A).

5. Put the ON/OFF switch in the "I" position.
6. Move the tool over the area to be cleaned.

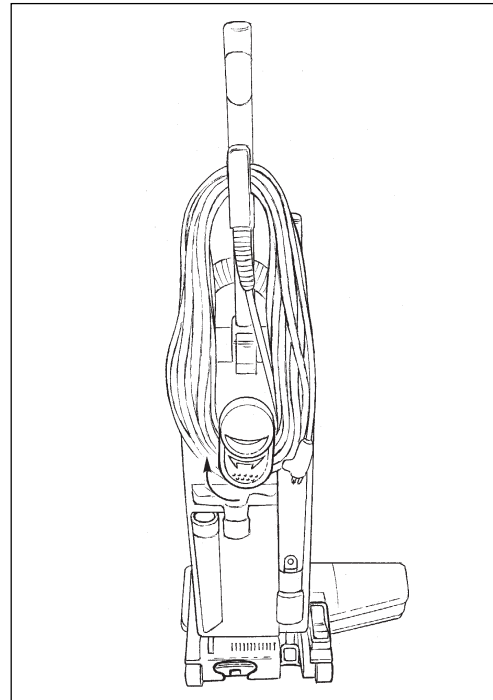

Figure 14

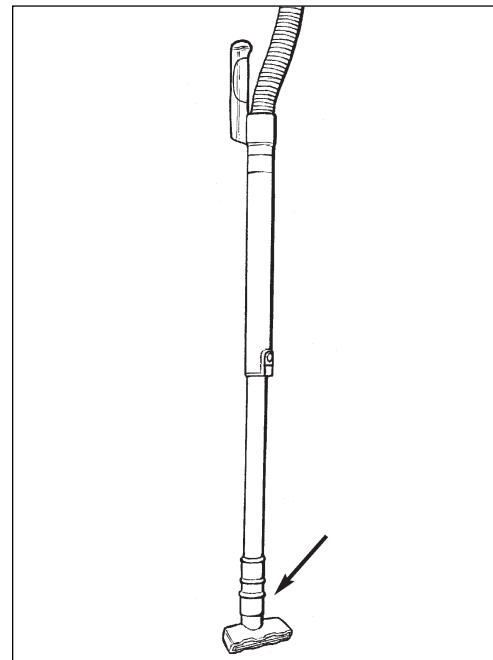

Figure 15

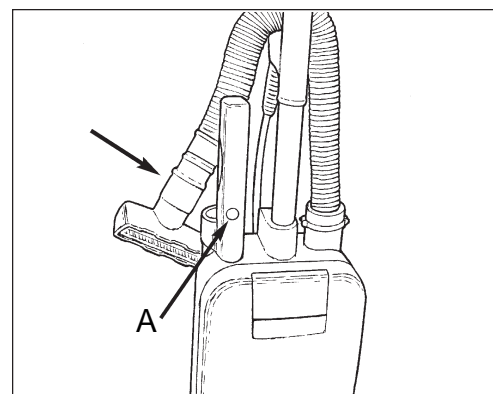

Figure 16

MAINTENANCE

⚠ WARNING: To prevent injury, always remove the electrical plug from the electrical outlet before doing any maintenance or repairs to the machine.

⚠ WARNING: Maintenance and repairs must be done by authorized personnel only. Use only genuine Clarke parts.

How To Change The Filter Bag

The machine uses a disposable paper filter bag. To change the paper filter bag, follow this procedure:

1. Make sure the ON/OFF switch in the "O" position and that the machine is disconnected from the power supply.
2. Open the front of the canister housing. To open the canister housing, lift the release handle (see figure 17).
3. Grasp cardboard inlet on both sides of the bag (see points A and B on figure 19) and slightly rotate and pull bag out.
5. Install a new filter bag. To install a new filter bag, follow this procedure:
 - a. Unfold the filter bag.
 - b. Hold the bag by the cardboard inlet.
 - c. Place the bottom of the cardboard inlet into the slot under the bag adaptor (see figure 18, item A)
 - d. Put the opening of the cardboard inlet over the bag adaptor (see figure 18, item B).
 - e. Make sure the cardboard is pushed all the way on the bag adaptor (figure 19) or the door will not latch.
 - f. Close the canister housing.

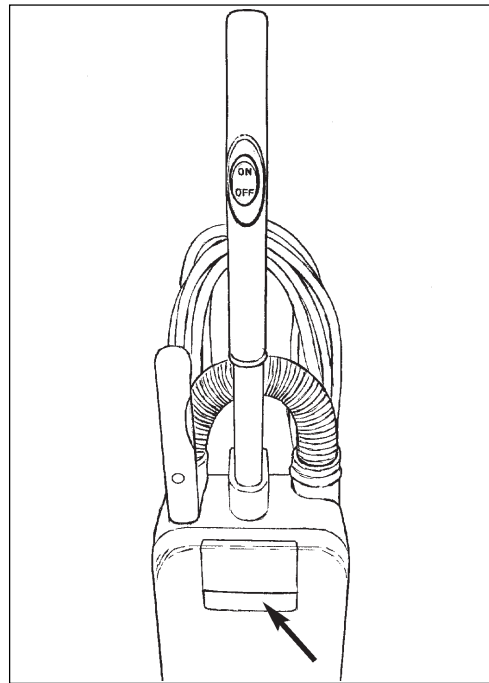

Figure 17

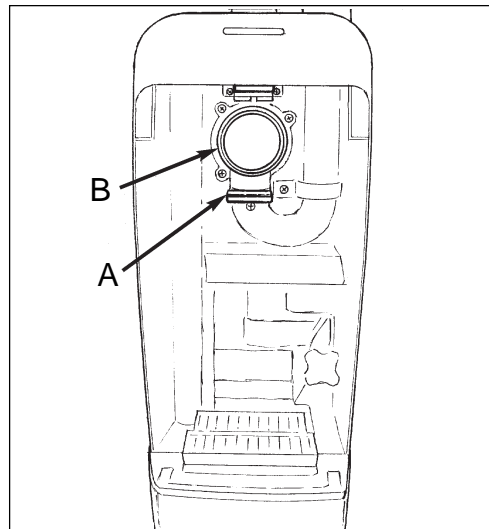

Figure 18

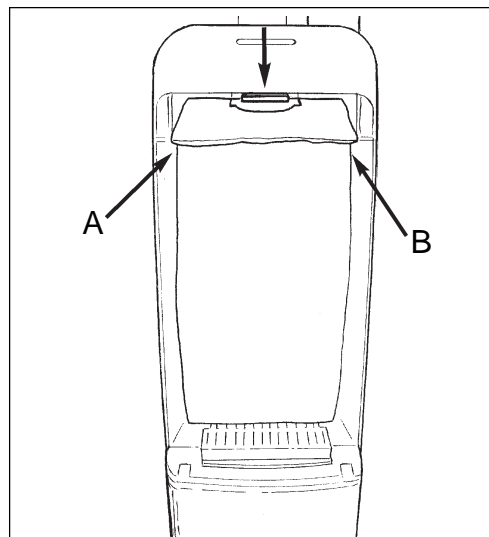

Figure 19

How To Change The Filter Cartridge

Change the filter cartridge whenever it is dirty or suction performance decreases. To change the filter cartridge, follow this procedure:

1. Make sure the ON/OFF switch is in the "O" position and the machine is disconnected from the power supply.
2. Open the canister door.
3. Remove the filter bag.
4. Remove the filter cartridge (see figure 20).
5. Replace filter cartridge and filter bag (see figure 21).

⚠ CAUTION: Check the filter cartridge while changing the paper bag. Replace the filter cartridge when dirty or when the vacuum suction performance drops off even with a clean filter bag.

How To Replace The Brush

⚠ WARNING: To prevent injury, unplug machine before cleaning or replacing brush. Brush may start suddenly and cause injury.

1. Put the machine on its side.
2. Turn the knobs which secure the nozzle plate. See figure 22.
3. Lift the nozzle plate up to remove it.
4. Lift the brush assembly up to remove it.
5. Install the new brush assembly.
6. Install the nozzle plate.
7. Put the machine on its wheels.

⚠ WARNING: To reduce the risk of injury from moving parts, unplug before servicing.

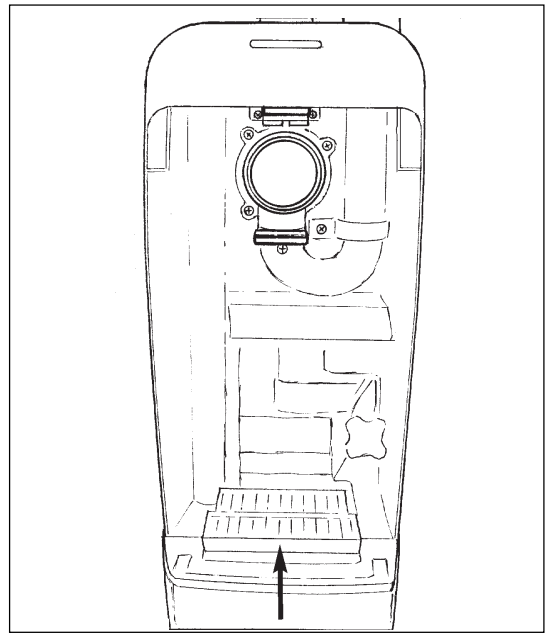

Figure 20

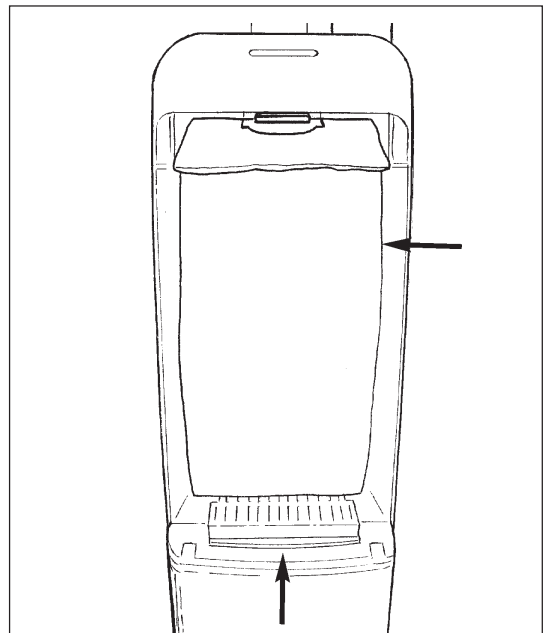

Figure 21

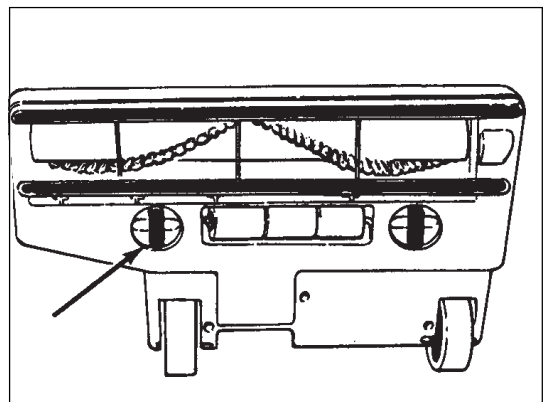

Figure 22

How To Change the Drive Belt

⚠ WARNING: To prevent injury, unplug machine before cleaning or replacing brush. Brush may start suddenly and cause injury.

To change the drive belt, follow this procedure:

1. Put the machine on its side.
2. Lift the nozzle plate up to remove it.
3. Lift the brush assembly up to remove it (see figure 23).
4. Remove the drive belt from the brush pulley.
5. Remove the drive belt from the motor shaft.
6. Put one end of the new drive belt around the motor shaft.
7. Put the other end of the drive belt around the brush pulley.
8. Install the brush assembly in the brush housing.
9. Install the nozzle plate.
10. Put the machine on its wheels.

⚠ WARNING: To reduce the risk of injury from moving parts, unplug before servicing.

The Vacuum Indicator Light

If the vacuum indicator light (1) comes on, (see figure 24) or the motor stops, do the following:

1. Put the ON/OFF switch in the "O" position (2).
2. Remove the electrical plug from the electrical outlet.
3. Check the vacuum hose for an obstruction. If there is an obstruction in the vacuum hose, remove the obstruction.
4. Check the brush assembly in the lower housing. If there is an obstruction in the brush assembly, remove the obstruction.
5. Check the filter bag. If the filter bag is over 1/2 full, change or empty the bag.
6. Check the filter cartridge. If the filter is dirty, change the filter.

Thermal Overload

A thermal overload is used to protect the vacuum motor. If the motor over heats, the thermal overload will stop the motor. If the motor stops, let the motor cool before restarting the machine. Check filters. If the motor continues to stop, consult an authorized service person.

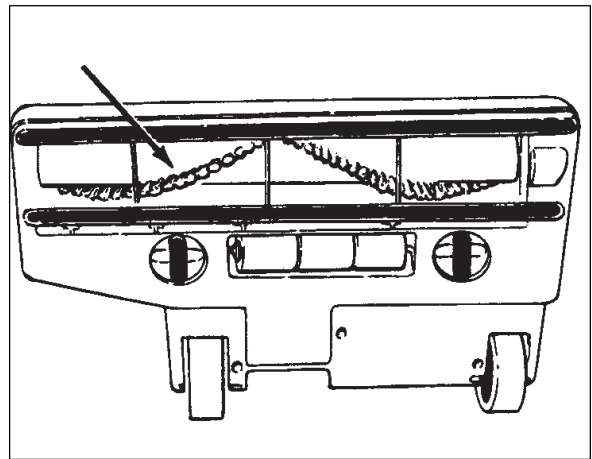

Figure 23

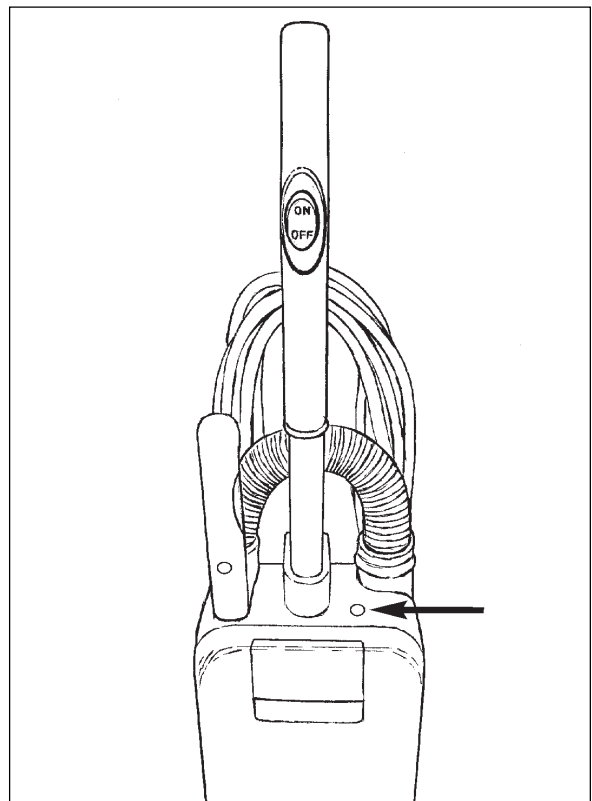

Figure 24

BRUSH PERFORMANCE INDICATOR LIGHTS

The D14 and D18 upright vacuums have 3 brush performance indicator lights (see figure 25). They are GREEN, YELLOW and RED. They work in the following manner:

Normal Operation:

- The GREEN light is on when the brush drive motor is on and the brush height setting is correct for the carpet.

NOTE: It is normal for the red or yellow light to intermittently turn on and off as high or low surfaces are encountered.

Brush Height Too High:

- The YELLOW light will continue to stay on when the brush height is too high for the carpet. Lower the brush height setting.

Brush Height Too Low or Brush Has Jammed:

- The RED light will continue to stay on when the brush height setting is too low for the carpet. Raise the brush height setting. The RED light will come on if the brush is jammed.
- If the RED light is on continuously for 10 seconds, the electronic safety stop will protect the brush motor by turning it off.
- To reset the brush drive motor, put the operating handle in the upright position. Turn the ON/OFF switch to the off position. Restart the machine.
- If the brush height was too low, raise the brush height setting.
- If the brush was jammed, unplug the vacuum and clear the brush.

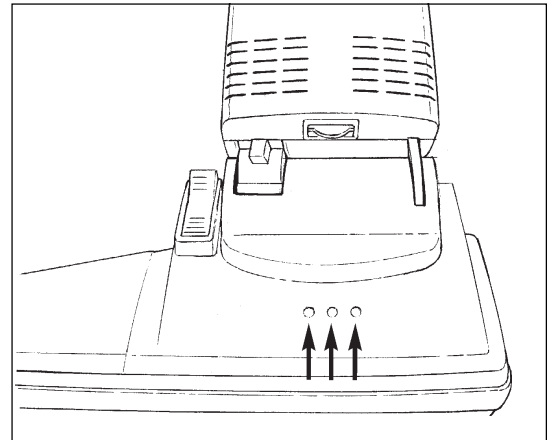

Figure 25

Clarke[®]

D14 & D18

Section II

Parts and Service Manual

(70720A)

Clarke®
D14 & D18
Drawing #1 Upper Canister Assembly 2/04

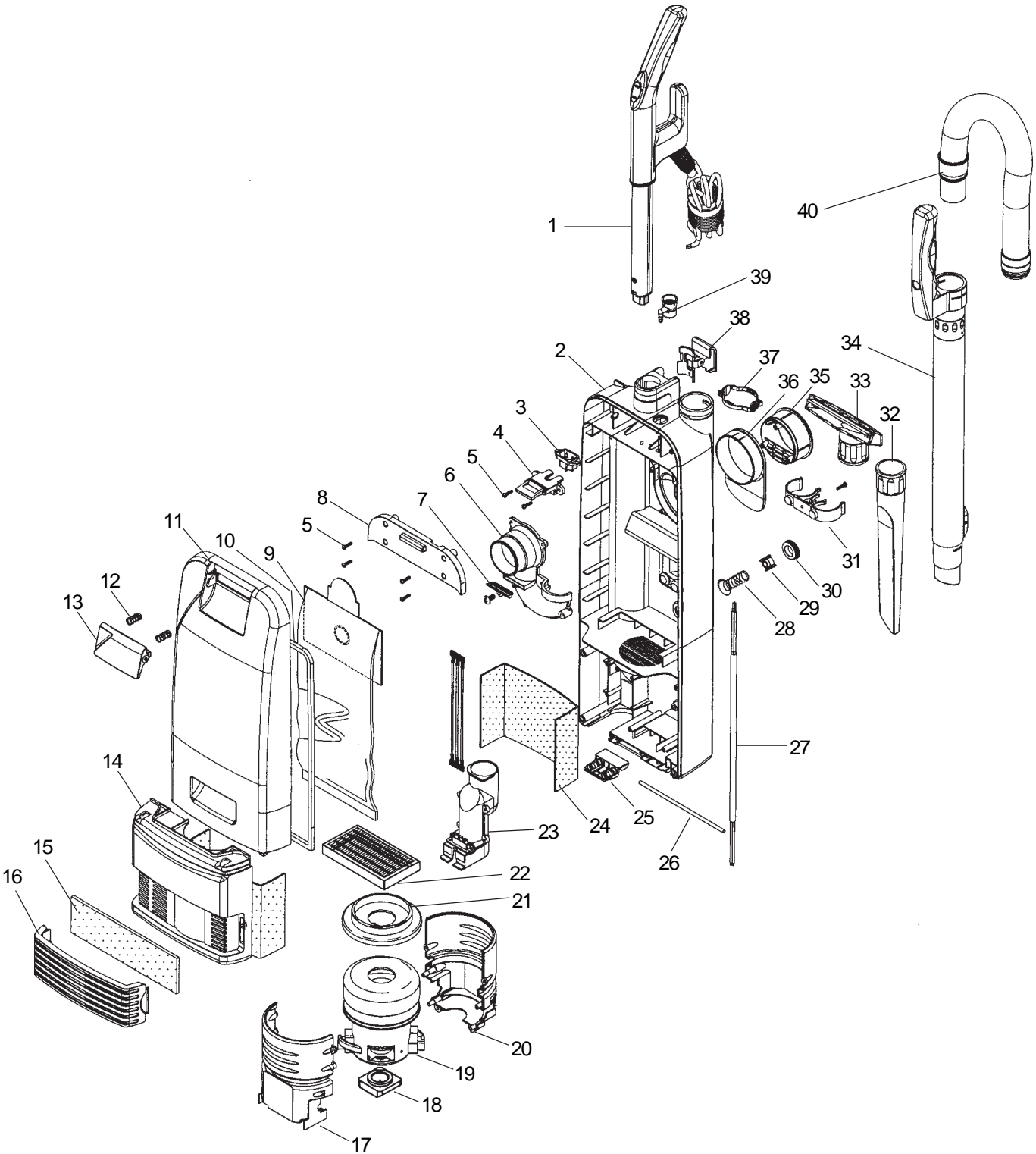

Clarke®
D14 & D18
Parts List #1 Upper Canister Assembly 2/06

Ref. No.	Part No.	Description	No. Req'd.
1	53296A	Handle Tube	1
1A	53199A	Handle, Left	1
1B	53207A	Handle, Right	1
1C	53320A	On/Off Switch	1
1D	53315A	Pad, Soft Touch	1
1E	53318A	Power Cord	1
1F	53233A	Receptacle, Handle	1
2	53211A	Canister, Rear (incl. #4, 5, 6, 7, 28, 29, 30, 35, 36)	1
3	53234A	Plug, Canister	1
4	53257A	Pivot, Filter Bag Asm.	1
5	53347A	Screw, M4 x 16	24
6	53213A	Adaptor, Air Inlet Asm. (incl. gaskets - 53307A & 53308A)	1
7	53258A	Guide, Bag Collar	1
8	53212A	Cover, w/Door Latch	1
9◆	50721B	Bag, Paper (pkg. 10)	1
10	53272A	Gasket, Door	1
11	53218A	Door, Asm. Canister (incl. #10, 12 & 13)	1
12	53330A	Spring, Door Catch	2
13	53219A	Latch, Canister Door	1
14	53215A	Cover, Asm. Vac Motor (incl. # 25 & 26)	1
15	53302A	Exhaust Filter	1
16	53217A	Cover, Exhaust Filter	1
17	53266A	Cover, 2 pc. Vac Motor	1
18	53271A	Spacer, Vacuum Motor	1
19	53324A	Motor, Vac. 120V (incls. #53356A)	1
	53358A	Carbon Brush	2
20		Same as 17 - 2pc. Set	1
21	53270A	Endcap, Vac Motor	1
22	53300A	Filter Cartridge	1
23	53256A	Channel, Airway Asm. (incl. receptacle)	1
24	53306A	Sound Insulation Set	1
25	53214A	Latch, Canister to Brush Hsg.	1
26	53274A	Pin, Canister to Brush Hsg.	1
27	53317A	Interconnect Cord	1
28	53328A	Spring, Air Valve	1
29	53240A	Plunger, Spring	1
30	53264A	Retainer, Air Valve	1
31	53252A	Retainer, Tools	1
32	53220A	Crevice Tool	1
33	53221A	Upholstery Tool w/Brush	1
34	53262A	Wand Assembly	1
35	53253A	Handle, Cord Hook	1
36	53254A	Swivel, Cord Hook	1
37	53255A	Retainer, Hose	2
38	53290A	Clamp, Asm. Handle (incl. 53210A & 53273A)	1
39	53235A	Bag Full Indicator	1
40	53225A	Hose Assembly	1
NI	53567A	O-Ring, Wand	1

NOTE: ◆ indicates a change has been made since the last publication of this manual.

Clarke®
D14 & D18
Drawing #2 Brush Housing Assembly 2/04

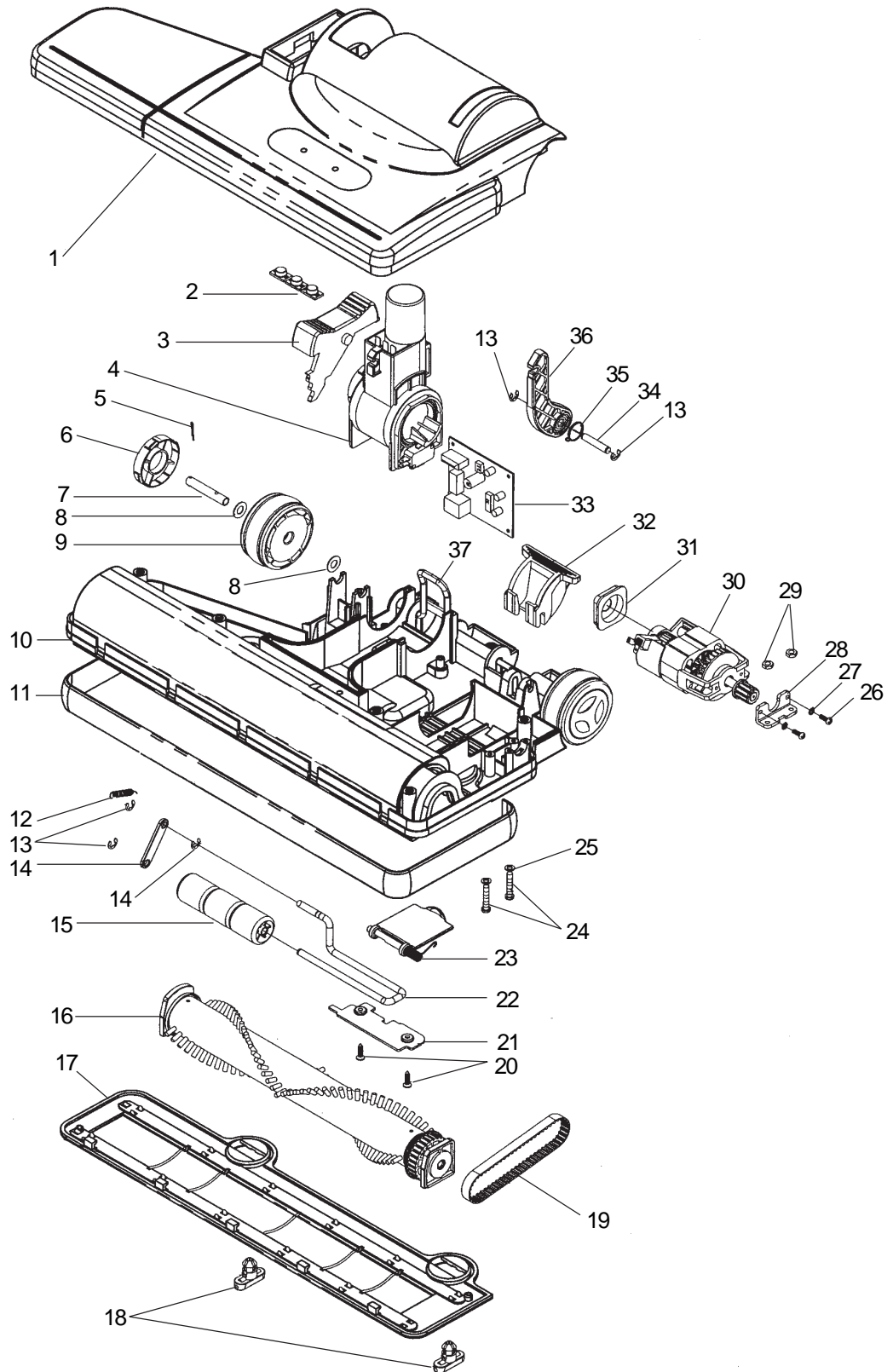

Clarke®
D14 & D18
Parts List #2 Brush Housing Assembly 7/04

Ref. No.	Part No.	Description	Qty.
1	53231A	Cover Asm., Brush Hsg. 14"	1
2	53232A	Cover Asm., Brush Hsg. 18" (cover asm. include #2)	1
3	53245A	Pedal, Brush Height	1
4	53242A	Pivot Asm., Airway (incl. 53236A; 53244A Bracket, Airway Right; & 53243A Bracket, Airway Left)	1
5		Cotter Pin	2
6	53259A	Hub Cap	2
7		Axle Hub	2
8	53291A	Spacer, Rear Wheel	4
9	53248A	Rear Wheel	2
10	53227A	Brush Housing Asm. 14"	1
	53228A	Brush Housing Asm. 18" (incl. 53312A, 53313A, 53263A (18))	1
11	53267A	Bumper 14"	1
	53268A	Bumper 18"	1
12	53331A	Spring, Brush Height Shaft	1
13	53355A	E-clips M6	4
14	53284A	Guide, Brush Height Shaft	1
15	53229A	Rollers	3
16	53260A	Brush Assembly 14"	1
	53261A	Brush Assembly 18"	1
17	53250A	Bottom Plate 14"	1
	53251A	Bottom Plate 18"	1
18	53263A	Tension Lever	2
19	53354A	Belt	1
20	53350A	Screw, Flathead M4 x 15	2
21	53286A	Retainer, Door and Rollers	1
22	53282A	Shaft, Rollers	1
23	53230A	Cleanout Door Asm. (incl. 53311A, 53278A & 53332A)	1
24		Screw, M5 - .8 x 24	2
25		Washer, M5	2
26	53348A	Screw, M4 - .7 x 10	2
27		Washer, M4	2
28	53285A	Bracket, Brush Motor	1
29		Nuts, M5 - .8	2
30	53325A	Motor, Brush 120V (incl. #26, 27, 28, 31 & 53298A)	1
31		Endcap, Brush Motor	1
32	53249A	Pedal, Foot Latch	1
33	53326A	Electronics 120V 14"	1
	40732A	Electronics 120V 18"	1
34	53275A	Pin, Support Pivot	1
35	53333A	Spring (include with #36)	1
36	53241A	Support Asm., Canister Pivot (includes #13, 34, 35)	1
37	53293A	Rear Axle (includes #7)	1
NI	53570A	Carbon Brush, Nozzle Motor	2

Clarke®
D14 & D18
Electrical Schematic 1/06

